



**AIR TORQUE**<sup>®</sup>



# 4th GENERATION PNEUMATIC ACTUATOR



**I N D E X**

Title	Page
▶ Design and construction.....	2 & 3
▶ Range of options.....	3
▶ Quality manufacturing.....	3
▶ Accessories available .....	3
▶ Multifunction-Indicator.....	4
▶ Ancillaries installation without Multi-function indicator.....	4
▶ 100% Travel stop adjustment.....	4
▶ Lock-Out option.....	4
▶ Operating conditions.....	5
▶ Operating function.....	5
▶ Fast acting operation.....	5
▶ Parts and materials.....	6
▶ ATB0 dimensions material and technical data.....	7
▶ Metric dimensions and technical data.....	8
▶ Imperial Dimensions and technical data.....	9
▶ Metric torque outputs.....	10 & 11
▶ Imperial torque outputs.....	12 & 13
▶ 120° and 180° Actuators.....	14
▶ 3 Position Actuators.....	15
▶ Sizing Information.....	15 & 16
▶ Protection levels available.....	17
▶ Full compliance with worldwide specifications.....	18
▶ How to order.....	19
▶ Quality product.....	19
▶ Standard documentation available.....	19
▶ Air Torque Sales Organization.....	20

**DESIGN**

The new 4th Generation rack and pinion pneumatic actuator has been designed, developed and tested incorporating the latest technology and materials available, with some innovative design features.

As a result of this product research we have obtained a high grade product with the following characteristics:

- ◆ Reliability
- ◆ High performance
- ◆ Wider product range permitting a more economical sizing selection
- ◆ Innovative and patented universal drive shaft and multifunction position indicator
- ◆ Full compliance with latest worldwide specifications
- ◆ A wide selection of highest levels of corrosion protection technology
- ◆ Aesthetically compact and modern style with no external cavities to avoid deposit build up

**CONSTRUCTION**

1. Extruded aluminium body, with both internal and external corrosion protection having honed cylinder surface for longer life and lower coefficient of friction.
2. Dual piston rack and pinion design for compact construction, symmetric mounting position, high-cycle life and fast operation, reverse rotation can be accomplished in the field by simply inverting the pistons.
3. Two independent external travel stop adjustments. Permits an easy and precise adjustment of +/- 4° in both directions, in the open and close positions for an accurate valve alignment.

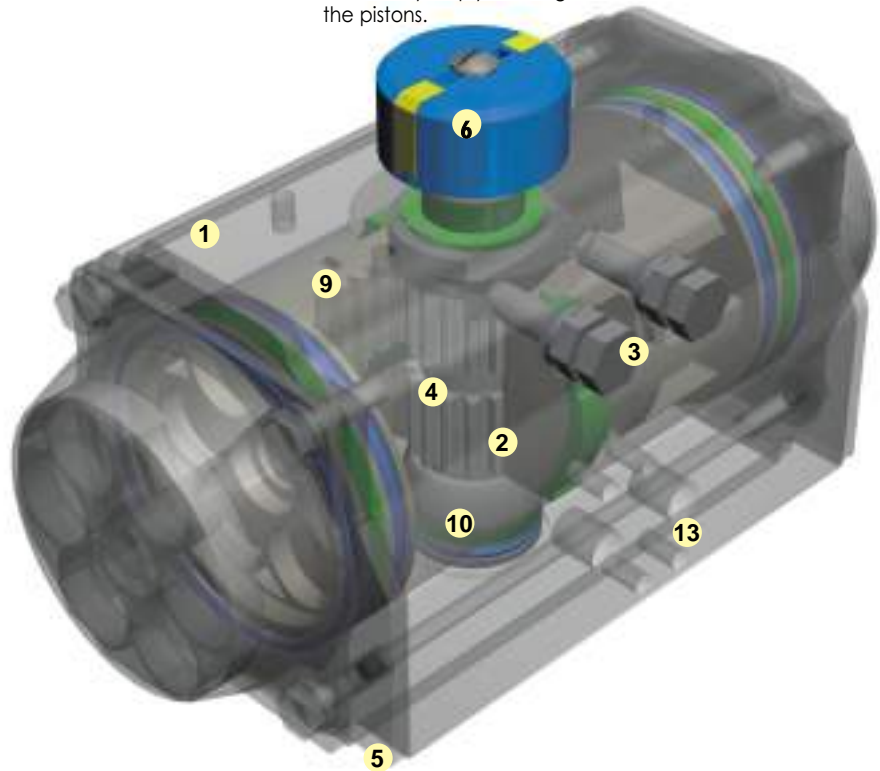

4. Universal and anti-blowout patented drive shaft for an easy conversion from parallel to diagonal square and vice versa. This feature permits a lower and more flexible stock.
5. One compact design with identical body and end caps for double acting and spring return models reducing inventory and allowing field conversion, by adding or removing modular spring cartridge.
6. Multifunction position indicator with Namur slot to allow: visual position indication, to fit and drive all accessories, to fit easily and economically the most popular sensors.



## CONSTRUCTION

7. Multiple bearings and guides on racks and pistons for precise operation, low friction, high cycle life and prevent shaft blowout.
8. Modular preloaded spring cartridge design. With coated spring for simple versatile range, greater safety and corrosion resistance.
9. Fully machined teeth on piston rack and pinion for accurate low backlash rack and pinion engagement and maximum efficiency.
10. Electroless nickel-plated blowout resistant, bearing guided one-piece pinion for improved safety and maximum cycle life.
11. Selected high quality bearings and seal for low friction, high cycle life and a wide operating temperature range.
12. Internal and external stainless steel fasteners for long term corrosion resistance.
13. Full conformance to the latest specifications: ISO 5211, DIN 3337 and VDI/VDE 3845 NAMUR for product interchangeability and easy mounting of solenoids, limit switches and other accessories.

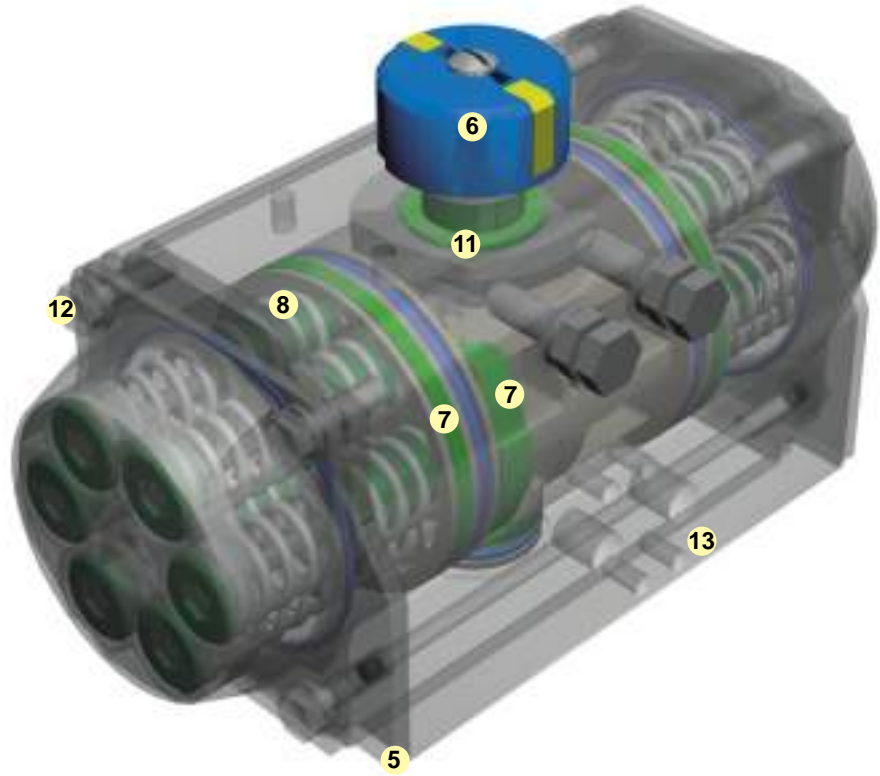

## RANGE OF OPTIONS, ACCESSORIES AND QUALITY MANUFACTURING

### RANGE OF OPTIONS

- A. With the 4th generation actuator we are able to offer 6 different levels of protections A, B, C, D, E, P. Please see table of protection levels available N° P01/99.
- B. Stainless steel 303 or 316 drive shaft is available on request on all sizes and all different protection levels .
- C. For high and low temperature applications FPM or Silicon O rings combined with a suitable lubricant are available for all models.
- D. 100% Adjustable travel stop.
- E. Economical Lock out capability in the fully-open or the fully-closed position.
- F. Multifunction Position indicator with S.S. metal inserts for proximity sensing.
- G. S.S. drive shaft Cover with namur slot for high temperature application and manual override.
- H. Other than the standard Parallel or Diagonal bottom drive shaft connection, we can supply Keyed drive connection, Flat head connection or special customized connections.
- I. 120° and 180° Actuator rotation and intermediate rotations like 135°.
- J. 3 position Actuators.

### QUALITY MANUFACTURING

- ◆ The AIR TORQUE actuators are manufactured under a quality system independently assessed and approved to ISO 9001.
- ◆ Every single actuator is factory tested and provided with a unique serial number for traceability.
- ◆ Each individual actuator is packed in a special proper cardboard carton with a clear and full description of the product for protection and easy identification.

### ACCESSORIES AVAILABLE

- ◆ Square drive reduction pieces for all drive shafts
- ◆ Centering/location ring for all sizes
- ◆ Brackets
- ◆ Couplings
- ◆ Solenoid valves
- ◆ Switch boxes
- ◆ Proximity sensors
- ◆ Gear boxes
- ◆ Positioners



The multi-function indicator which is supplied as standard on 4th Generation Actuator and manufactured in composite material is suitable for:

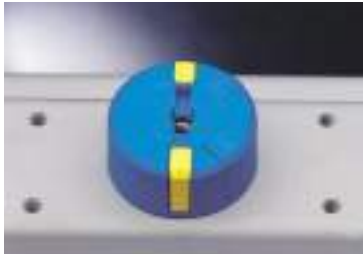

1. Position indication  
Visual indication of the Actuator/Valve position is shown via a color coded insert and Namur slot. The indicator is suitable for all types of drive shaft and either direction of actuator rotation.

2. Actuator ancillary drive  
The Namur drive slot in the position indicator permits direct drive engagement of switchboxes and positioners.



3. Direct mounting of sensors  
The indicator can be supplied with metal inserts to permit easy and economical installation of many types of sensors: P+F, IFM, TURK, etc.

### ANCILLARIES INSTALLATION WITHOUT MULTI-FUNCTION INDICATOR

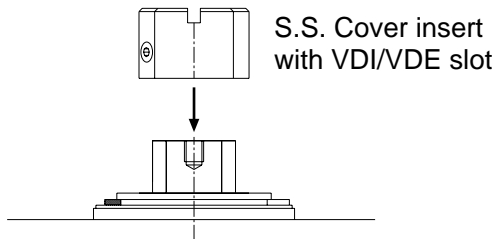

The 4th Generation actuator can be supplied upon request with a S.S. Cover that replaces the standard indicator and has the Namur drive slot permitting:

1. Fitment of ancillaries such as switchboxes and positioners
2. Indication of actuator position via the Namur slot
3. Operate at high temperature
4. Manual operation of the actuator in cases of emergency.

### 100% TRAVEL STOP ADJUSTMENT ON 4TH GENERATION ACTUATOR

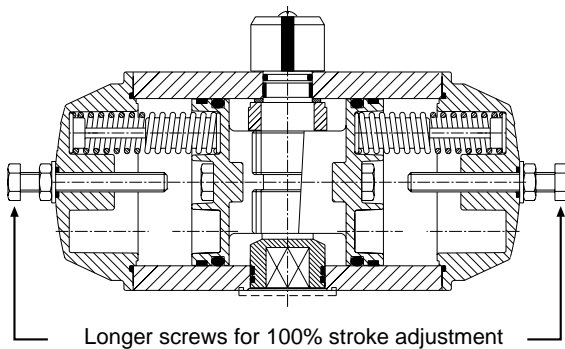

The 4th Generation standard actuator provides stroke adjustment of + or - 4° in both directions 0° and 90°. When a stroke of less than 90° is required e.g. 1°, 5°, 10°, 25°, 50°, 80°, etc. the actuator can be supplied with special bolts in both End-Caps to allow stroke adjustment or limitation, from 0° to 90° according to customer requirements. The 100% TRAVEL STOP ADJUSTMENT is available on all of the 4th Generation actuator range.

### LOCK-OUT CAPABILITY IN FULLY-OPEN OR FULLY-CLOSED POSITION

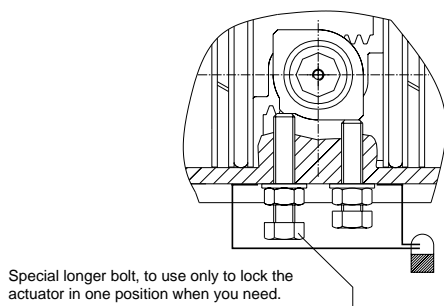

The 4th generation actuator offers an economical solution when is requested to locking the actuator in the fully-open (90°) or fully-closed (0°) position. The actuator can be supplied with a special bolt and locking device to permanently lock the actuator in position by using a padlock and preventing unwanted operation.



## 1. Operating media:

Dry or lubricated air or inert/non-corrosive gases on condition that they are compatible with internal actuator parts and lubricant. The operating media must have a dew point equal to -20°C (-40°F) or at least 10°C below the ambient temperature. The maximum particle size must not exceed 30 µ.

## 2. Supply pressure:

For Double Acting and Spring Return actuators the maximum supply pressure is: 8 Bar (116 PSI). Minimum supply pressure is 2.5 Bar (36 PSI).

## 3. Operating Temperature:

\* Standard product from -20°C (-4°F) to +80°C (+176°F)

\* Low temperature LT actuator with silicon "O" rings from -40°C (-40°F) to +80°C (+176°F)

\* High temperature HT actuator with FPM "O" rings from -15°C (+5°F) to +150°C (+300°F)

Caution: For low and high temperature service, special grease is required. Please contact AIR TORQUE for each application. High and low temperature will vary the output torque of the actuator.

## 4. Stroke:

The stroke for AIR TORQUE actuators is as follows (See technical data):

\* Standard construction: 90° rotation with stroke adjustment at 0° and 90° + or - 4°

\* Type Y 120° stroke: 120° rotation with stroke adjustment at 0° and 120° + or - 4°

\* Type X 180° stroke: 180° rotation with stroke adjustment at 0° and 180° + or - 4°.

## 5. Operating Time:

See Technical Data Sheet

## 6. Lubrication:

Actuators are factory lubricated for the life under normal operating conditions.

The standard lubricant is suitable for use from -20°C (-40°F) to +80°C (+176°F).

For low (LT) and high (HT) temperature service, where special grease is required please contact AIR TORQUE.

## 7. Construction:

Twin piston rack and pinion actuator design suitable for both indoor and outdoor installation.

## 8. Protection and Corrosion resistance:

Actuators are supplied with corrosion protections for normal environments. For severe duties select from the protection level table or contact AIR TORQUE.

## 9. Actuator designation and Marking:

The actuator type, size, operating pressure, output torque, direction of rotation, orientation of failure mode, operating temperature and drive type are determined by actuator designation. AIR TORQUE actuators are supplied with a label showing all this informations: type, model (including protection and if applicable the LT or HT for operating temperature), stroke, maximum permissible supply pressure, direction of rotation, output torque, ancillary mounting detail, pressure connection, actuator/valve mounting detail and serial number.

## OPERATING FUNCTION AND DIRECTION OF ROTATION

The standard rotation is clockwise to close, counter-clockwise rotation is achieved when port 2 is pressurised.

For actuator marked LF the rotation is counter-clockwise to close, clockwise rotation is obtained when port 2 is pressurised

### Double Acting operation function (standard rotation) TOP View:

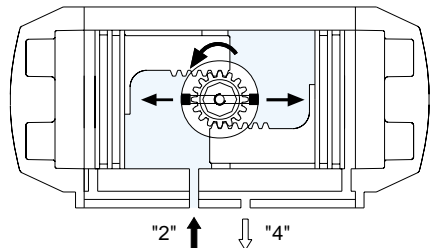
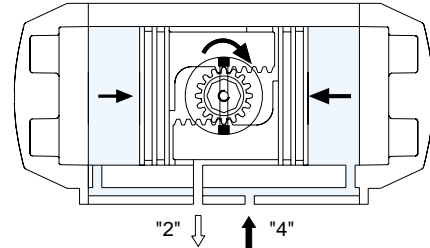
<p>Air supplied to Port 2 forces the pistons apart and towards the actuators end caps, with the exhaust air exiting at Port 4, a counter-clockwise rotation is achieved.</p>  <p style="text-align: center;">"2" ↑   ↓ "4"</p>	<p>Air supplied to Port 4 forces the pistons together with exhaust air exiting at Port 2, a clockwise rotation is achieved.</p>  <p style="text-align: center;">"2" ↓   ↑ "4"</p>
---	--

### Single Acting operation function (standard rotation) TOP View:

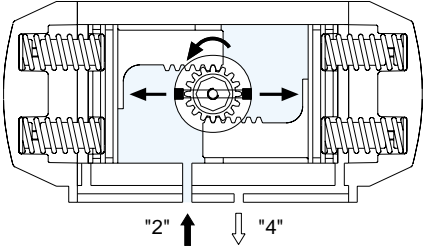
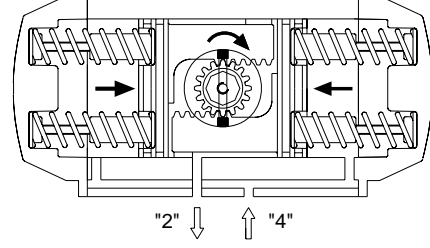
<p>Air supplied to Port 2 forces the pistons apart and toward the actuator end caps, compressing the springs with the exhaust air existing at Port 4, a counter clockwise rotation is achieved.</p>  <p style="text-align: center;">"2" ↑   ↓ "4"</p>	<p>On loss of air pressure (air or electric failure) at Port 2 allows the springs to force the pistons together with the exhaust air exiting at Port 2, a clockwise rotation is achieved.</p>  <p style="text-align: center;">"2" ↓   ↑ "4"</p>
--	--

## FAST ACTING ACTUATORS

Upon request AIR TORQUE actuators can be specially manufactured for fast acting operations. The normal life span of the actuators is associated with the normal operating time.

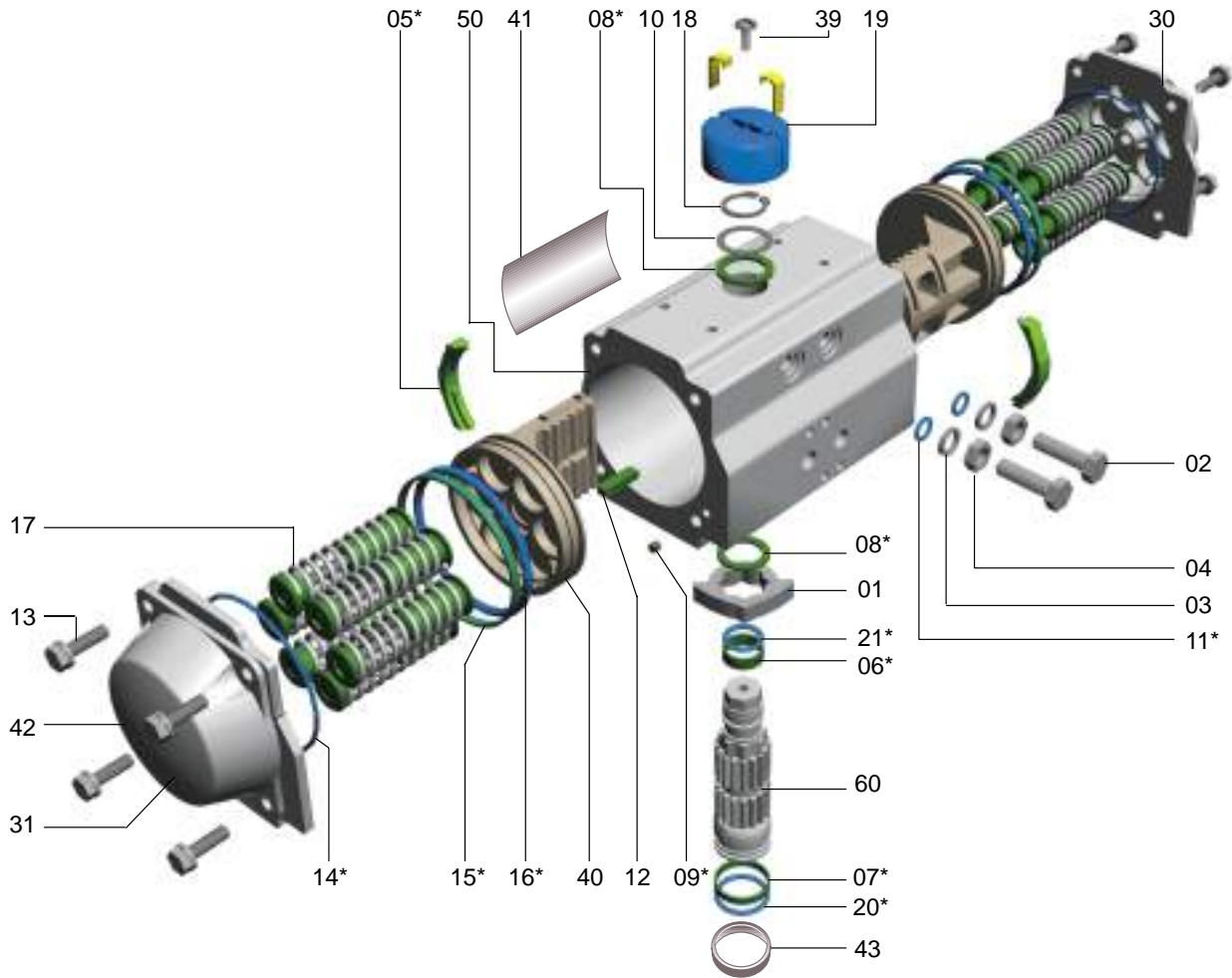

PART N°	Spare Parts	UNIT Q.TY	PART DESCRIPTION	STANDARD MATERIAL	CORROSION PROTECTION "A" (A)	OPTIONAL MATERIAL
01		1	OCTI-CAM (Stop arrangement)	Stainless Steel (B)	-----	-----
02		2	STOP CAP SCREW	Stainless Steel	-----	-----
03		2	WASHER	Stainless Steel	-----	-----
04		2	NUT (Stop screw)	Stainless Steel	-----	-----
05*	☞	2	BEARING (Piston back)	Polyphthalamide	-----	-----
06*	☞	1	BEARING (Pinion top)	Nylon 46	-----	-----
07*	☞	1	BEARING (Pinion bottom)	Nylon 46	-----	-----
08*	☞	2	THRUST BEARING (Pinion)	Polyphthalamide	-----	-----
09*	☞☐	2	PLUG	Nitrile (NBR)	-----	FPM --- Silicon
10		1	THRUST WASHER (Pinion)	Stainless Steel	-----	-----
11*	☞☐	2	"O" RING (Stop screw)	Nitrile (NBR)	-----	FPM --- Silicon
12		2	PISTON GUIDE	*Polyphthalamide + GF	-----	-----
13		8 (c)	CAP SCREW (End cap)	Stainless Steel	-----	-----
14*	☞☐	2	"O" RING (End cap)	Nitrile (NBR)	-----	FPM --- Silicon
15*	☞	2	BEARING (Piston head)	Polyphthalamide	-----	-----
16*	☞☐	2	"O" RING (Piston)	Nitrile (NBR)	-----	FPM --- Silicon
17		min.5 max.12	SPRING (Cartridge)	High alloy Spring Steel	Epoxy coated	-----
18		1	SPRING CLIP (Pinion)	Spring Steel	Nickel plated	Stainless Steel
19		1	POSITION INDICATOR	Polypropylene +GF	-----	-----
20*	☞☐	1	"O" RING (Pinion bottom)	Nitrile (NBR)	-----	FPM --- Silicon
21*	☞☐	1	"O" RING (Pinion top)	Nitrile (NBR)	-----	FPM --- Silicon
30 (a)		1	RIGHT END CAP	Die Cast Aluminium alloy	Polyester coated	-----
31 (a)		1	LEFT END CAP	Die Cast Aluminium alloy	Polyester coated	-----
39		1	CAP SCREW (Indicator)	Stainless Steel	-----	-----
40		2	PISTON	Die Cast Aluminium alloy	Anodized	-----
41		1	ACTUATOR IDENTIFICATION LABEL	Polyester-Aluminium	-----	-----
42		2	END CAP LABEL	Polyester-Aluminium	-----	-----
43		1	SPIGOT (Only on request)	Extruded Aluminium alloy	ALODUR	-----
50		1	BODY	Extruded Aluminium alloy	ALODUR	-----
60		1	DRIVE SHAFT	Steel alloy	Nickel plated	Stainless Steel

\* Suggested SPARE PARTS For maintenance

☞ Parts included in spare parts kit

☐ Parts included in "O" ring kit

Notes: (A) For other protection levels available see page 17

(B) For models A1350 and bigger the OCTI-CAM material is cast iron

(C) For model A1700 and model A\*800 the Cap screws are 12 pcs

(D) For models A1550 and bigger the 2 End Caps are symmetric

# ATBO DIMENSIONS, MATERIAL AND TECHNICAL DATA



**AIR TORQUE**

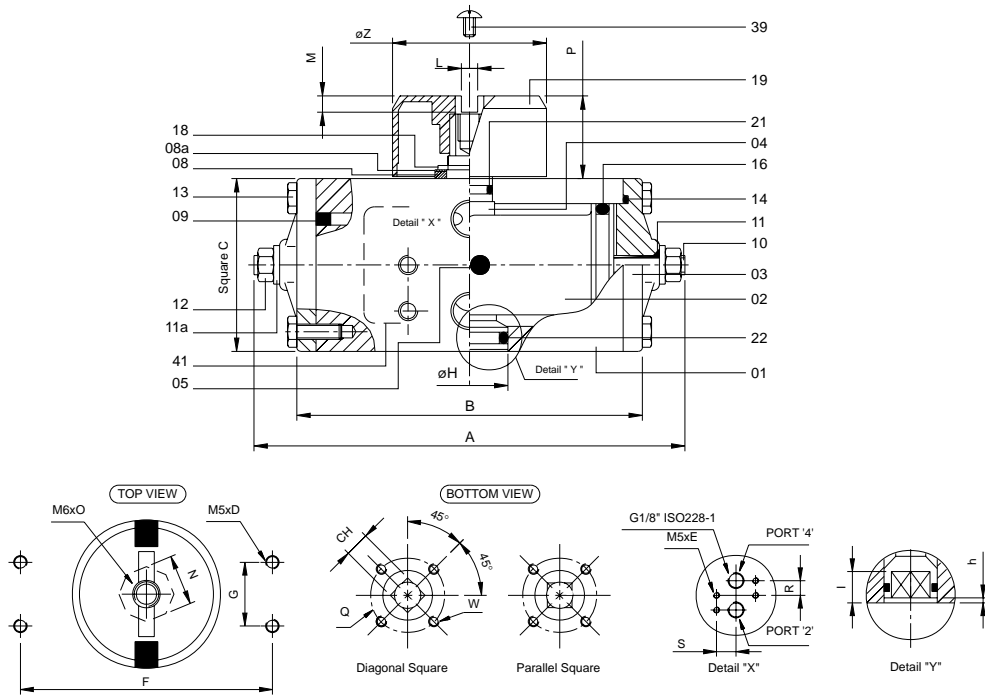

**DIMENSIONS IN mm AND inches**

Dimensions:	mm	Inch
A	115	4.53
B	94	3.70
Square C	45	1.77
D	7	0.28
E	4,5	0.18
F	50	1.97
G	25	0.98
H	20	0.79
I min.	10	0.39
L	4	0.16
M	4,5	0.18
N	11	0.43
O	12	0.47
P	20	0.79
Q	36	1.42
R	12	0.47
S	16	0.63
W	M5x8	M5x0.31
Z	40	1.57
CH	9	0.35
h min.	0,5	0.02
ISO Flange	F03	F03

PART N°	Spare Parts	UNIT Q.TY	PART DESCRIPTION	STANDARD MATERIAL	CORROSION PROTECTION "A" (A)	OPTIONAL MATERIAL
01		1	BODY	Extruded Aluminium alloy	ALODUR	-----
02		2	PISTON	Polyphthalamide + GF	-----	-----
03		2	END CAP	Polyphthalamide + GF	-----	-----
04		1	DRIVE SHAFT	Steel alloy	Nickel plated	Stainless Steel
05*	⊙	2	BEARING (Piston back)	Nylon 46	-----	-----
08*	⊙	1	THRUST BEARING (Pinion)	Nylon 46	-----	-----
08a	⊙	1	THRUST WASHER (Pinion)	Stainless Steel	-----	-----
09*	⊙ □	2	PLUG	Nitrile (NBR)	-----	FPM --- Silicon
10		2	SCREW (Ext. stroke adjustment)	Stainless Steel	-----	-----
11*	⊙ □	2	"O" RING (Screw seal)	Nitrile (NBR)	-----	FPM --- Silicon
11a		2	WASHER	Stainless Steel	-----	-----
12		2	NUT (Stop adjustment)	Stainless Steel	-----	-----
13		8	CAP SCREW (End cap)	Stainless Steel	-----	-----
14*	⊙ □	2	"O" RING (End cap)	Nitrile (NBR)	-----	FPM --- Silicon
16*	⊙ □	2	"O" RING (Piston)	Nitrile (NBR)	-----	FPM --- Silicon
18		1	SPRING CLIP (Pinion)	Spring Steel	Nickel plated	Stainless Steel
19		1	POSITION INDICATOR	Polypropylene +GF	-----	-----
21*	⊙ □	1	"O" RING (Pinion top)	Nitrile (NBR)	-----	FPM --- Silicon
22*	⊙ □	1	"O" RING (Pinion bottom)	Nitrile (NBR)	-----	FPM --- Silicon
39		1	CAP SCREW (Indicator)	Stainless Steel	-----	-----
41		1	ACTUATOR IDENTIFICATION LABEL	Polyester-Aluminium	-----	-----

\* Suggested SPARE PARTS For maintenance

Notes: (A) For other protection levels available see page 17

⊙ Parts Included in spare parts kit

□ Parts Included in "O" ring kit

DOUBLE ACTING TORQUE RATINGS IN Nm												
Supply Pressure	2,5 Bar	3 Bar	3,5 Bar	4 Bar	4,2 Bar	4,5 Bar	5 Bar	5,5 Bar	6 Bar	7 Bar	8 Bar	
AT BO D	3.0	3.6	4.2	4.8	5.1	5.4	6.1	6.7	7.3	8.5	9.7	

DOUBLE ACTING TORQUE RATINGS IN LB-IN										
Supply Pressure	40 Psi	50 Psi	60 Psi	70 Psi	80 Psi	90 Psi	100 Psi	110 Psi	116 Psi	
AT BO D	29,5	36,9	44,3	51,7	59,1	66,5	73,9	81,2	85,7	

	Metrics		Imperial	
	φ mm	32	φ inch	1,257
Chamber	L	0,04	Cu. In.	2.4
Air volume opening	L	0,04	Cu. In.	2.4
Air volume closing	L	0,04	Cu. In.	2.4
Opening Time (A)	Sec.	0,15	Sec.	0,15
Closing Time (A)	Sec.	0,15	Sec.	0,15
Approximate Weight	Kg	0,45	Lbs	0,98

Notes: The indicated moving time of the actuator is obtained in the following test conditions: (1) Room Temperature, (2) Actuator Stroke 90°, (3) Solenoid Valve with Orifice Of 4 mm and a flow capacity Qn 400 L/min., (4) Inside pipe diameter 8 mm, (5) Medium clean air, (6) Air supply pressure 5,5 bar (79,75 Psi), (7) Actuator without external resistance load.

Caution: obviously on the field applications when one or more of the above parameter are different, the moving time will be different.

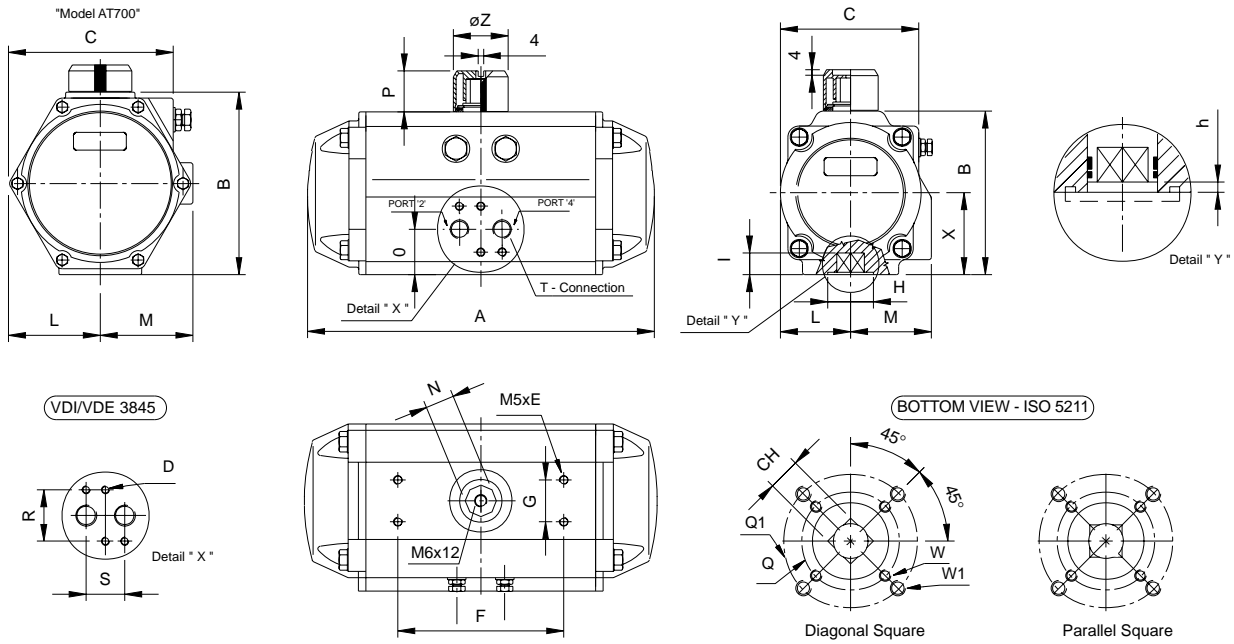

	ACTUATOR MODEL	AT050	AT100	AT200	AT250	AT300	AT350	AT400	AT450	AT500	AT550	AT600	AT650	AT700	AT800
		D/S	D/S	D/S	D/S	D/S	D/S	D/S	D/S	D/S	D/S	D/S	D/S	D/S	D/S
Dimensions in mm	A	140.5	158.5	216.5	247.5	268.5	315	345	408.5	437.5	487	543	621	684	
	B	69	85	102	115	127	145	157	177	196	220.5	245	298.5	330	
	C	59	72	84.5	97.5	111	127	136	156.5	165	190.7	213	251	298.5	
	D	M5x8	M5x8	M5x8	M5x8	M5x8	M5x8	M5x8	M5x8	M5x8	M5x8	M5x8	M6x10	M6x10	
	E	4	8	8	8	8	8	8	8	8	8	8	8	8	
	F	80	80	90	80	80	80	80	80	80	130	130	130	130	
	G	30	30	30	30	30	30	30	30	30	30	30	30	30	
	H	30	35	35	55	55	70	70	85	85	100	100	130	130	
	I min.	12	16	6	19	19	24	24	29	29	38	38	48	48	
	L	29	36	42.5	49.5	56	64	69.5	80	88	99	110	131	163.5	
	M	41.5	47	52	56.8	67	77	82	91.5	99	105	112	131	166	
	N	11	11	19	19	19	27	27	27	27	42	42	42	42	
	O	28.5	30	30.5	32.5	37.5	42.5	45	47	52	58	62	78.5	165	
	P	20	20	20	20	20	30	30	30	30	50	50	50	50	
	Q	42	50	50	70	70	102	102	125	125	140	140	165	165	
	Q1	-	-	-	-	-	-	-	-	-	-	-	-	-	
	R	32	32	32	32	32	32	32	32	32	32	32	45	45	
S	24	24	24	24	24	24	24	24	24	24	24	40	40		
W	M5	M4	M6	M8	M8	M10	M10	M12	M12	M12	M16	M20	M20		
W1	-	-	-	-	-	-	-	-	-	-	-	-	-		
T - ISO 228	1/8"	1/8"	1/8"	1/8"	1/4"	1/4"	1/4"	1/4"	1/4"	1/4"	1/4"	1/4"	3/8"	1/2"	
ISO Flange	F04	F05	F05	F07	F07	F10	F10	F12	F12	F14	F14	F14	F16	F16	
CH	1	14	14	17	17	22	22	27	27	36	36	46	46		
h min.	3.5	0.5	1.5	1.5	1.5	1.5	1.5	1.5	1.5	2	2	2.5	2.5		
X	34.5	42.5	51	57.5	63.5	72.5	78.5	88.5	98	111.5	122	150.5	165		
Z	40	40	40	40	40	56/65	56/65	65	65	80/115	80/115	115	115		
Options	ISO Flange	F03	F04	F05-F07	F05-F07	F05 F07	F07 F10	F07-F10	F10-F12	F10-F12	F12	F12	F14	F14	
	Q	36	42	50	50	70	70	70	102	102	125	125	140	140	
	Q1	-	-	70	70	102	102	102	125	125	-	-	-	-	
	W	M5	M5	M6	M6	M8	M8	M8	M10	M10	M12	M12	M16	M16	
	W1	-	-	M8	M8	M8	M10	M10	M12	M12	-	-	-	-	
	H	25	30	35	40	40	55	55	70	70	85	85	100	112	
	CH	9	11	17	17	17	22	22	27	27	27	27	36	36	
I min.	13	12	19	19	19	24	24	29	29	29	29	38	38		

METRIC	MODEL TYPE	AT 050	AT 100	AT 200	AT 250	AT 300	AT 350	AT 400	AT 450	AT 500	AT 550	AT 600	AT 650	AT 700	AT 800												
		D S	D S	D S	D S	D S	D S	D S	D S	D S	D S	D S	D S	D S	D S												
Chamber	φ (mm)	50	63	75	88	100	115	125	145	160	180	200	240	265													
Screw stroke Adjustment	For 1° adjusted	1/6 turn	1/6 turn	1/6 turn	1/5 turn	1/5 turn	1/5 turn	1/4 turn	1/5 turn	1/4 turn	1/4 turn	1/4 turn	1/4 turn	1/4 turn													
Air Volume Opening	(l)	0.09	0.16	0.31	0.51	0.71	1.19	1.54	2.41	3.14	4.26	5.94	10	14.5													
Air Volume Closing	(l)	0.15	0.26	0.49	0.78	1.11	1.8	2.34	3.78	4.92	6.89	9.46	15.2	21.38													
Opening Time (s)	(Sec.)	0.2 0.25	0.25 0.3	0.3 0.35	0.4 0.5	0.5 0.6	0.7 0.8	0.9 1.1	1.2 1.4	1.5 1.7	2 2.2	2.7 3.2	3.5 4	4 4.5													
Closing Time (s)	(Sec.)	0.25 0.3	0.3 0.35	0.4 0.5	0.5 0.6	0.7 0.9	0.9 1.1	1.2 1.4	1.5 1.8	1.8 2.1	2.4 2.8	3.5 4	4.1 4.6	4.5 5													
Approximate weight	(kg)	0.96	1.06	1.58	1.7	2.7	3.15	3.8	4.4	5.4	6.51	8.4	9.84	10.2	12.6	14.5	18.1	19.8	24	25	31.6	35.5	45.1	53	64	83	102

Notes: (A) The above indicated moving time of the actuator, are obtained in the following test conditions: (1) Room Temperature, (2) Actuator Stroke 90°, (3) Solenoid Valve with Orifice Of 4 mm and a flow capacity Qn 400 L/min., (4) Inside pipe diameter 8 mm, (5) Medium clean air, (6) Air supply pressure 5.5 bar (79.75Psi), (7) Actuator without external resistance load.  
 Cautions: obviously on the field applications when one or more of the above parameter are different, the moving time will be different.



# IMPERIAL DIMENSIONS AND TECHNICAL DATA



**AIR TORQUE**

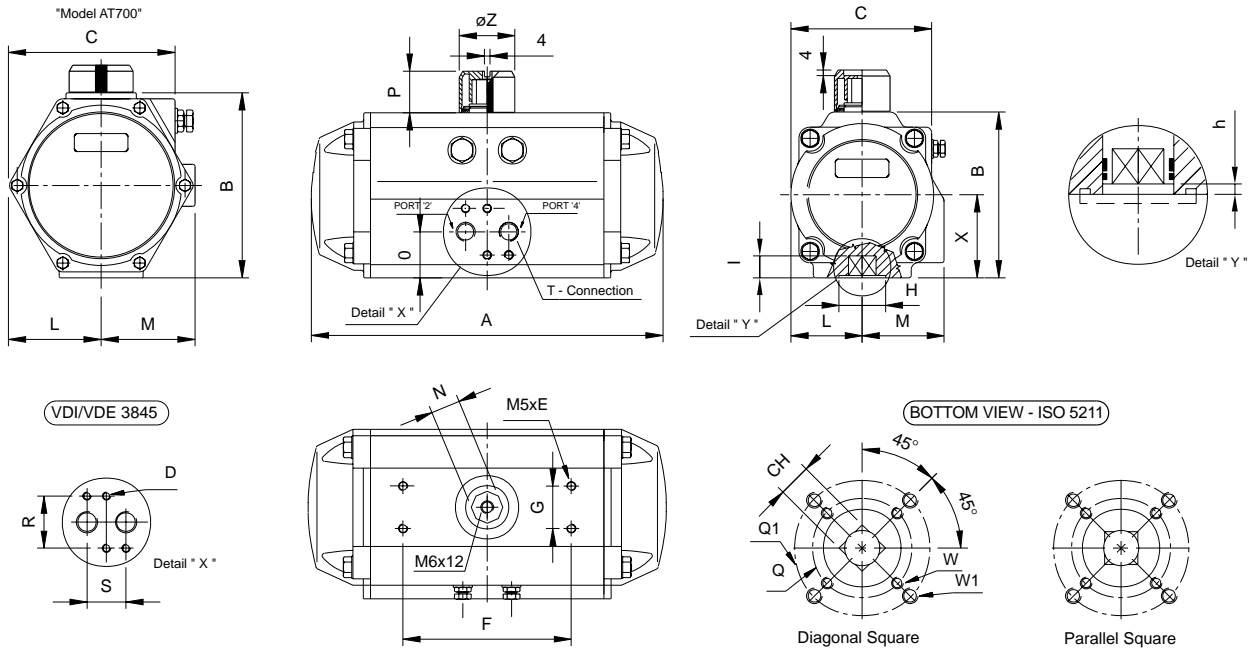

	Dimensions in inch														
	ACTUATOR MODEL	AT050 D/S	AT100 D/S	AT200 D/S	AT250 D/S	AT300 D/S	AT350 D/S	AT400 D/S	AT450 D/S	AT500 D/S	AT550 D/S	AT600 D/S	AT650 D/S	AT700 D/S	AT800 D/S
A	5.53	6.24	8.29	9.74	10.57	12.40	13.58	16.08	17.22	19.17	21.38	24.45	26.93	-	-
B	2.72	3.35	4.02	4.53	5.00	5.71	6.18	6.97	7.72	8.68	9.65	11.75	12.99	-	-
C	2.32	2.83	3.33	3.84	4.37	5.00	5.35	6.16	6.65	7.51	8.39	9.88	11.75	-	-
D	M5x8	M5x8	M5x8	M5x8	M5x8	M5x8	M5x8	M5x8	M5x8	M5x8	M5x8	M6x10	M6x10	-	-
E	0.16	0.31	0.31	0.31	0.31	0.31	0.31	0.31	0.31	0.31	0.31	0.31	0.31	-	-
F	3.15	3.15	3.15	3.15	3.15	3.15	3.15	3.15	3.15	3.15	3.15	3.15	3.15	-	-
G	1.18	1.18	1.18	1.18	1.18	1.18	1.18	1.18	1.18	1.18	1.18	1.18	1.18	-	-
H	1.18	1.38	1.38	2.17	2.17	2.76	2.76	3.35	3.35	3.94	3.94	5.12	5.12	-	-
I min.	0.47	0.63	0.63	0.75	0.75	0.94	0.94	1.14	1.14	1.50	1.50	1.89	1.89	-	-
L	1.14	1.42	1.67	1.95	2.20	2.52	2.74	3.15	3.46	3.90	4.35	5.16	6.44	-	-
M	1.63	1.85	2.05	2.24	2.64	3.03	3.23	3.60	3.90	4.13	4.41	5.16	6.54	-	-
N	0.43	0.43	0.75	0.75	0.75	1.06	1.06	1.06	1.06	1.65	1.65	1.65	1.65	-	-
O	1.04	1.18	1.20	1.28	1.48	1.67	1.77	1.85	2.05	2.28	2.44	3.09	6.50	-	-
P	0.79	0.79	0.79	0.79	0.79	1.18	1.18	1.18	1.16	1.97	1.97	1.97	1.97	-	-
Q	1.65	1.97	1.97	2.76	2.76	4.02	4.02	4.92	4.92	5.51	5.51	6.50	6.50	-	-
Q1	-	-	-	-	-	-	-	-	-	-	-	-	-	-	-
R	1.26	1.26	1.26	1.26	1.26	1.26	1.26	1.26	1.26	1.26	1.26	1.77	1.77	-	-
S	0.94	0.94	0.94	0.94	0.94	0.94	0.94	0.94	0.94	0.94	0.94	1.57	1.57	-	-
W	M5	M6	M6	M6	M8	M10	M10	M12	M12	M16	M16	M20	M20	-	-
W1	-	-	-	-	-	-	-	-	-	-	-	-	-	-	-
T - ISO 228	1/8	1/8	1/8	1/8	1/4	1/4	1/4	1/4	1/4	1/4	1/4	3/8	1/2	-	-
ISO Flange	F04	F05	F05	F07	F07	F10	F10	F12	F12	F14	F14	F16	F16	-	-
CH	0.43	0.55	0.55	0.67	0.67	0.87	0.87	1.06	1.06	1.42	1.42	1.81	1.81	-	-
h min.	0.02	0.02	0.06	0.06	0.06	0.06	0.06	0.06	0.06	0.08	0.08	0.10	0.10	-	-
X	1.36	1.67	2.01	2.26	2.50	2.85	3.09	3.48	3.86	4.39	4.80	5.93	6.50	-	-
Z	1.57	1.57	1.57	1.57	1.57	2.21 / 2.56	2.21 / 2.56	2.56	2.56	3.15 / 4.53	3.15 / 4.53	4.53	4.53	-	-
Options	ISO Flange	F03	F04	F05-F07	F05-F07	F05-F07	F07-F10	F07-F10	F10-F12	F10-F12	F12	F12	F14	F14	-
	Q	1.42	1.65	1.97	1.97	1.97	2.76	2.76	4.02	4.02	4.92	4.92	5.51	5.51	-
	Q1	-	-	2.76	2.76	2.76	4.02	4.02	4.92	4.92	5.51	5.51	6.50	6.50	-
	W	M5	M5	M6	M6	M6	M8	M8	M10	M10	M12	M12	M16	M16	-
	W1	-	-	M8	M8	M8	M10	M10	M12	M12	-	-	-	-	-
	H	0.98	1.18	1.57	1.57	1.57	2.17	2.17	2.76	2.76	3.35	3.35	3.94	4.41	-
	CH	0.35	0.43	0.67	0.67	0.67	0.87	0.87	1.06	1.06	1.06	1.06	1.42	1.42	-
	I min.	0.39	0.47	0.75	0.75	0.75	0.95	0.94	1.14	1.14	1.24	1.24	1.50	1.50	-

IMPERIAL	MODEL TYPE	AT 050		AT 100		AT 200		AT 250		AT 300		AT 350		AT 400		AT 450		AT 500		AT 550		AT 600		AT 650		AT 700		AT 800		
		D	S	D	S	D	S	D	S	D	S	D	S	D	S	D	S	D	S	D	S	D	S	D	S	D	S	D	S	
Chamber	φ (inch)	1.97		2.48		2.95		3.46		3.94		4.53		4.92		5.71		6.35		7.09		7.87		9.45		10.43				
Screw stroke Adjustment	For 1° adjustment	1/8 turn		1/6 turn		1/6 turn		1/5 turn		1/5 turn		1/5 turn		1/4 turn		1/5 turn		1/4 turn		1/4 turn		1/4 turn		1/4 turn		1/4 turn		1/4 turn		
Air Volume Opening	(Cu. In.)	5.5		9.8		18.9		31.1		43.3		72.6		94.0		147.1		191.6		260.0		362.5		610.2		884.6				
Air Volume Closing	(Cu. In.)	9.2		15.9		29.9		47.6		67.7		109.8		142.8		230.7		300.2		420.5		577.3		927.6		1304.7				
Opening Time (ms)	(Sec.)	0.2	0.25	0.25	0.3	0.3	0.35	0.4	0.5	0.5	0.6	0.7	0.8	0.9	1.1	1.2	1.4	1.5	1.7	2	2.2	2.7	3.2	3.5	4	4	4.5			
Closing Time (ms)	(Sec.)	0.25	0.3	0.3	0.35	0.4	0.5	0.5	0.6	0.7	0.9	0.9	1.1	1.2	1.4	1.5	1.8	1.8	2.1	2.4	2.8	3.5	4	4.1	4.6	4.5	5			
Approximate weight	(lbs.)	2.1		2.3		3.5		3.7		5.9		6.9		8.4		9.7		11.9		14.4		18.5		21.7		22.5		27.8		

**Notes:** (A) The above indicated moving time of the actuator, are obtained in the following test conditions: (1) Room Temperature, (2) Actuator Stroke 90°, (3) Solenoid Valve with Orifice of 4 mm and a flow capacity Qn 400 L/min., (4) Inside pipe diameter 8 mm, (5) Medium clean air, (6) Air supply pressure 5.5 bar (79.75Psi), (7) Actuator without external resistance load.

**Cautions:** obviously on the field applications when one or more of the above parameter are different, the moving time will be different.



		SPRING RETURN TORQUE RATINGS IN Nm																Spring stroke							
Supply Pressure	Actuator Spring	2.5 Bar		3 Bar		3.5 Bar		4 Bar		4.2 Bar		4.5 Bar		5 Bar		5.5 Bar		6 Bar		7 Bar		8 Bar		90°	
Model	Set	Start	End	Start	End	Start	End	Start	End	Start	End	Start	End	Start	End	Start	End	Start	End	Start	End	Start	End	Start	End
AT 050	S 05	4.9	3.4	6.6	5.1	8.3	6.8	9.9	8.4	10.6	9.1	11.6	10.1	13.2	11.7									4.9	3.4
	S 06	4.3	2.5	5.9	4.1	7.6	5.8	9.3	7.4	9.9	8.1	10.9	9.1	12.6	10.8	14.2	12.4							5.8	4
	S 07			5.3	3.1	6.9	4.8	8.6	6.5	9.2	7.1	10.2	8.1	11.9	9.8	13.6	11.5	15.2	13.1					6.8	4.7
	S 08					6.2	3.8	7.9	5.5	8.6	6.2	9.6	7.2	11.2	8.8	12.9	10.5	14.6	12.1	17.9	15.5			7.8	5.4
	S 09							7.2	4.5	7.9	5.2	8.9	6.2	10.6	7.8	12.2	9.5	13.9	11.2	17.2	14.5	20.5	17.8	8.8	6.1
	S 10											8.2	5.2	9.9	6.9	11.5	8.5	13.2	10.2	16.5	13.5	19.8	16.8	9.7	6.7
	S 12													9.2	5.9	10.9	7.6	12.5	9.2	15.9	12.5	19.2	15.9	10.7	7.4
AT 100	S 05	9.1	6.2	12	9.2	15.0	12.1	17.9	15.0	19.1	16.2	20.8	17.9	23.8	20.9									8.4	5.5
	S 06	8	4.5	10.9	7.5	13.9	10.4	16.8	13.3	18	14.5	19.7	16.3	22.7	19.2	25.6	22.1							10.1	6.7
	S 07			9.8	5.8	12.8	8.7	15.7	11.6	16.9	12.8	18.6	14.6	21.5	17.5	24.5	20.4	27.4	23.4					11.8	7.8
	S 08					11.6	7	14.6	10	15.7	11.1	17.5	12.9	20.4	15.8	23.4	18.7	26.3	21.7	32.2	27.5			13.5	8.9
	S 09							13.5	8.3	14.6	9.4	16.4	11.2	19.3	14.1	22.3	17.1	25.2	20	31.1	25.9	36.9	31.7	15.2	10
	S 10											15.3	9.5	18.2	12.4	21.1	15.4	24.1	18.3	29.9	24.2	35.8	30	16.9	11.1
	S 12													17.1	10.8	20	13.7	23	16.6	28.8	22.5	34.7	28.3	18.6	12.2
AT 200	S 05	18.0	11.8	23.8	17.6	29.7	23.4	35.5	29.2	37.8	31.6	41.3	35	47.1	40.9									17.3	11.1
	S 06	15.8	8.3	21.6	14.1	27.5	19.9	33.3	25.8	35.6	28.1	39.1	31.6	44.9	37.4	50.7	43.2							20.8	13.3
	S 07			19.4	10.7	25.2	16.5	31.1	22.3	33.4	24.6	36.9	28.1	42.7	33.9	48.5	39.8	54.3	45.6					24.2	15.5
	S 08					23	13	28.8	18.8	31.2	21.2	34.7	24.7	40.5	30.5	46.3	36.3	52.1	42.1	63.7	53.7			27.7	17.7
	S 09							26.6	15.4	29	17.7	32.5	21.2	38.3	27.0	44.1	32.8	49.9	38.6	61.5	50.3	73.2	61.9	31.2	19.9
	S 10											30.2	17.7	36.1	23.6	41.9	29.4	47.7	35.2	59.3	46.8	71	58.5	34.6	22.1
	S 12													33.8	20.1	39.7	25.9	45.5	31.7	57.1	43.4	68.7	55	38.1	24.3
AT 250	S 05	27.4	16.9	36.6	26	45.7	35.2	54.9	44.3	58.5	48	64	53.5	73.2	62.6									28.9	18.3
	S 06	23.8	11.1	32.9	20.3	42.1	29.4	51.2	38.6	54.9	42.2	60.4	47.7	69.5	56.9	78.7	66							34.7	22
	S 07			29.2	14.5	38.4	23.6	47.5	32.8	51.2	36.4	56.7	41.9	65.8	51.1	75	60.2	84.2	69.4					40.4	25.7
	S 08					34.7	17.9	43.9	27	47.5	30.7	53	36.2	62.2	45.3	71.3	54.5	80.5	63.6	98.8	81.9			46.2	29.3
	S 09							40.2	21.2	43.9	24.9	49.4	30.4	58.5	39.5	67.7	48.7	76.8	57.8	95.1	76.1	113	94.5	52	33
	S 10											45.7	24.6	54.8	33.8	64	42.9	73.1	52.1	91.5	70.4	110	88.7	57.8	36.7
	S 12													51.2	28	60.3	37.1	69.5	46.3	87.8	64.6	106	82.9	63.5	40.3
AT 300	S 05	41.1	27.1	54.4	40.4	67.7	53.7	81	67	86.3	72.3	94.3	80.3	108	93.6									39.4	25.3
	S 06	36.1	19.2	49.4	32.5	62.7	45.8	76	59.1	81.3	64.4	89.3	72.4	103	85.7	116	99							47.3	30.4
	S 07			44.3	24.6	57.6	37.9	70.9	51.2	76.2	56.5	84.2	64.5	97.5	77.8	111	91.1	124	104					55.1	35.5
	S 08					52.5	30	65.8	43.3	71.1	48.7	79.1	56.6	92.4	69.9	106	83.2	119	96.5	146	123			63	40.5
	S 09							60.8	35.5	66.1	40.8	74	48.8	87.3	62.1	101	75.3	114	86.6	141	115	167	142	70.9	45.6
	S 10											69	40.9	82.3	54.2	95.6	67.5	109	80.8	135	107	162	134	78.8	50.7
	S 12													77.2	46.3	90.5	59.6	104	72.9	130	99	157	126	86.7	55.7
AT 350	S 05	66.5	41.9	87.9	63.4	109	84.9	131	106	140	115	152	128	174	149									65.5	41
	S 06	58.3	28.8	79.7	50.3	101	71.8	123	93.3	131	102	144	115	166	136	187	158							78.6	49.2
	S 07			71.5	37.2	93	58.7	115	80.2	123	88.8	136	102	158	123	179	145	200	166					91.7	57.4
	S 08					84.8	45.6	106	67.1	115	75.7	128	88.6	149	110	171	132	192	153	235	196			105	65.6
	S 09							98.1	54	107	62.6	120	75.5	141	97	163	118	184	140	227	183	270	226	118	73.8
	S 10											111	62.4	133	83.9	154	105	176	127	219	170	262	213	131	82
	S 12													125	70.8	146	92.3	168	114	211	157	254	200	144	90.2
AT 400	S 05	86	56.1	113.7	83.8	141	111	169	139	180	150	197	167	224	195									82	52.5
	S 06	75.5	39.6	103.2	67.3	131	95	159	123	170	134	186	150	214	178	242	206							99	63
	S 07			92.7	50.8	120.4	78.5	148	106	159	117	176	134	203	162	231	189	259	217					115	73.5
	S 08					110	62	137.6	89.7	149	101	165	117	193	145	221	173	248	201	304	256			132	84
	S 09							127	73.3	138	84.3	155	101	182	129	210	156	238	184	293	239	349	295	149	94.5
	S 10											144	84.5	172	112	200	140	227	168	283	223	338	278	165	105
	S 12													161	95.7	189	123	217	151	272	206	328	262	181	116
AT 450	S 05	135	88.6	179	132	222	176	265	219	283	236	309	262	352	306									129	82
	S 06	119	62.8	162	106	206	150	249	193	266	211	293	237	336	280	379	324							155	99
	S 07			146	80.5	189	124	233	167	250	185	276	211	320	254	363	298	406	341					180	115
	S 08					173	98.2	216	142	233	159	260	185	303	229	347	272	390	316	477	403			206	132
	S 09							200	116	217	133	243	159	287	203	330	246	374	290	460	377	547	464	232	148
	S 10											227	134	270	177	314	221	357	264	444	351	531	438	258	165
	S 12													254	151	297	195	341	238	428	325	515	412	283	181
AT																									

# METRIC TORQUE RATINGS



# AIR TORQUE

SPRING RETURN TORQUE RATINGS IN Nm														Spring stroke											
Supply Pressure		2.5 Bar		3 Bar		3.5 Bar		4 Bar		4.2 Bar		4.5 Bar		5 Bar		5.5 Bar		6 Bar		7 Bar		8 Bar		90° Start	0° End
Actuator Model	Spring Sef	0° 90°		0° 90°		0° 90°		0° 90°		0° 90°		0° 90°		0° 90°		0° 90°		0° 90°		0° 90°		0° 90°			
		Start	End	Start	End	Start	End	Start	End	Start	End	Start	End	Start	End	Start	End	Start	End	Start	End	Start	End		
AT 600	S 05	319	217	426	323	532	430	638	536	681	578	745	642	851	749									315	213
	S 06	277	154	383	260	489	367	596	473	638	515	702	579	808	686	915	797							378	255
	S 07			341	197	447	304	553	410	596	453	660	516	766	623	872	729	979	835					441	298
	S 08					404	241	511	347	553	390	617	453	723	560	830	666	936	772	1149	985			504	340
	S 09							468	284	511	327	575	390	681	497	787	603	894	709	1106	922	1319	1135	567	383
	S 10											532	327	638	434	745	540	851	646	1064	859	1277	1072	630	425
	S 11													596	371	702	477	809	583	1027	796	1234	1009	693	468
S 12															660	414	766	520	979	733	1192	946	756	510	
AT 650	S 05	533	372	712	551	890	730	1069	908	1141	980	1248	1087	1426	1266									521	360
	S 06	461	268	640	447	818	625	997	804	1068	876	1176	983	1354	1162	1533	1340							625	433
	S 07			568	343	746	521	925	700	996	771	1104	879	1282	1057	1461	1236	1640	1415					730	505
	S 08					674	417	853	596	924	667	1032	774	1210	953	1389	1132	1568	1310	1925	1668			834	577
	S 09							781	491	852	563	959	670	1138	849	1317	1028	1495	1204	1853	1564	2210	1921	938	649
	S 10											887	566	1066	745	1245	923	1423	1102	1787	1459	2138	1817	1042	721
	S 11													994	640	1173	819	1351	998	1709	1355	2066	1713	1146	793
S 12															1101	715	1279	894	1637	1251	1994	1508	1251	865	
AT 700	S 05	751	496	1011	755	1270	1015	1529	1274	1635	1378	1789	1533	2048	1793									801	546
	S 06	642	336	902	595	1161	854	1420	1114	1524	1217	1680	1373	1939	1632	2198	1892							961	655
	S 07			792	435	1052	694	1311	954	1415	1057	1570	1213	1830	1472	2089	1732	2349	1997					1121	764
	S 08					943	534	1202	793	1306	897	1467	1053	1721	1312	1980	1571	2239	1837	2758	2350			1281	873
	S 09							1093	633	1197	737	1352	893	1612	1152	1871	1411	2130	1677	2649	2189	3168	2708	1442	982
	S 10											1243	732	1503	992	1762	1251	2021	1510	2540	2029	3059	2548	1602	1091
	S 11													1393	832	1653	1091	1912	1350	2431	1869	2950	2388	1762	1200
S 12															1544	931	1803	1190	2322	1709	2840	2228	1922	1309	
AT 800	S 05																								
	S 06																								
	S 07																								
	S 08																								
	S 09																								
	S 10																								
	S 11																								
S 12																									

\* Of the above values are the output torque that remain available to operate the valve when the port "2" is pressurized.  
Springs

Out-put torque available when air supply fails

DOUBLE ACTING TORQUE RATINGS IN Nm											
Supply Pressure Model	2.5 Bar	3 Bar	3.5 Bar	4 Bar	4.2 Bar	4.5 Bar	5 Bar	5.5 Bar	6 Bar	7 Bar	8 Bar
AT 050 D	8.3	10.0	11.6	13.3	14.0	15.0	16.6	18.3	19.9	23.3	26.6
AT 100 D	14.7	17.6	20.5	23.5	24.6	26.4	29.3	32.2	35.2	41.0	46.9
AT 200 D	29.1	34.9	40.7	46.5	48.9	52.4	58.2	64.0	69.8	81.4	93.1
AT 250 D	45.8	54.9	64.1	73.2	76.9	82.4	91.5	101	110	128	146
AT 300 D	66.5	79.8	93.1	106	112	120	133	146	160	186	213
AT 350 D	107	129	150	172	181	193	215	236	258	301	344
AT 400 D	138	166	194	222	233	249	277	305	332	388	443
AT 450 D	217	261	304	348	365	391	435	478	522	609	696
AT 500 D	284	340	397	454	477	511	567	624	681	794	908
AT 550 D	383	459	536	613	643	689	766	842	919	1072	1225
AT 600 D	532	638	745	851	893	957	1064	1170	1276	1489	1702
AT 650 D	893	1072	1251	1430	1501	1608	1787	1966	2144	2502	2859
AT 700 D	1297	1556	1815	2075	2179	2334	2594	2853	3112	3631	4150
AT 800 D											

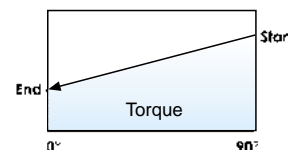
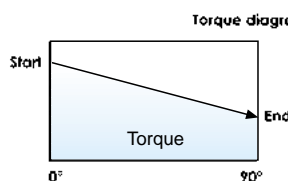
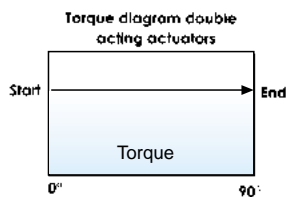



Supply Pressure		SPRING RETURN TORQUE RATINGS IN LB-IN																		Spring stroke	
		40 Psi		50 Psi		60 Psi		70 Psi		80 Psi		90 Psi		100 Psi		110 Psi		116 Psi			
		0°	90°	0°	90°	0°	90°	0°	90°	0°	90°	0°	90°	0°	90°	0°	90°	0°	90°		
Actuator Model	Spring Set	Start	End	Start	End	Start	End	Start	End	Start	End	Start	End	Start	End	Start	End	Start	End	Start	End
AT 050	S 05	51.3	38	71.6	58.3	91.9	78.6	112	98.9	132	119	153	139	173	160					43.1	29.8
	S 06	45.4	29.4	65.6	49.7	85.9	70	106	90.3	127	111	147	131	167	151	187	171			51.8	35.8
	S 07	39.4	20.8	59.7	41.1	80	63	100	81.6	121	102	141	122	161	142	181	163	194	175	60.4	41.8
	S 08			53.7	32.4	74	52.7	94.3	73	115	93	135	114	155	134	175	154	188	166	69	47.7
	S 09					68	44.1	88.3	64.4	109	85	129	105	149	125	169	146	182	158	77.6	53.7
	S 10							82.4	55.8	103	76	123	96.3	143	117	163	137	176	149	86.3	59.7
	S 11									96.7	67.4	117	87.7	137	108	158	128	170	140	94.9	65.6
	S 12													131	99	152	120	164	132	104	71.6
AT 100	S 05	94	68.5	130	104	166	140	201	176	237	212	273	247	309	283					74.7	49.1
	S 06	84.2	53.5	120	89.3	156	125	192	161	227	197	263	232	299	268	335	304			89.6	58.9
	S 07	74.4	38.6	110	74.4	146	110	182	146	218	182	253	218	289	253	325	289	346	311	105	68.8
	S 08			100	59.5	136	95.2	172	131	208	167	243	203	279	238	315	274	337	296	119	78.6
	S 09					126	80.3	162	116	198	152	234	188	269	223	305	259	327	281	134	88.4
	S 10							152	101	188	137	224	173	260	209	295	244	317	266	149	98.2
	S 11									178	122	214	158	250	194	286	229	307	251	164	108
	S 12													240	179	276	214	297	236	179	118
AT 200	S 05	186	131	257	202	328	273	399	344	470	415	541	486	612	557					153	97.8
	S 06	167	100	238	171	309	242	380	313	451	384	522	455	593	526	664	597			184	117
	S 07	147	70	218	141	289	212	360	283	431	354	502	425	573	496	644	567	687	609	214	137
	S 08			198	110	269	181	340	252	419	323	483	394	554	465	625	536	667	579	245	157
	S 09					250	150	321	221	392	292	463	363	534	434	605	505	648	548	276	176
	S 10							301	191	372	262	443	333	514	404	585	475	628	517	306	194
	S 11									353	231	424	302	495	373	566	444	608	487	337	215
	S 12													475	342	546	413	589	456	368	235
AT 250	S 05	285	191	396	303	508	415	620	526	731	638	843	750	955	862					256	162
	S 06	252	140	476	252	476	364	587	475	699	587	811	699	922	810	1034	922			307	195
	S 07	220	89	331	201	443	313	555	424	667	536	778	648	890	759	1002	871	1069	938	358	227
	S 08			299	150	411	261	522	373	634	485	746	597	858	708	969	820	1036	887	409	260
	S 09					378	210	490	322	602	434	713	545	825	657	937	769	1004	836	460	292
	S 10							457	271	569	383	681	494	793	606	904	718	971	785	511	325
	S 11									537	331	648	443	760	555	872	667	939	734	562	357
	S 12													728	504	639	416	906	683	613	389
AT 300	S 05	425	301	587	463	750	625	912	787	1074	950	1236	1112	1399	1274					349	224
	S 06	380	231	542	393	705	555	867	718	1029	880	1192	1042	1354	1205	1516	1367			418	269
	S 07	335	161	498	323	660	486	822	648	984	810	1147	973	1309	1135	1471	1297	1569	1395	488	314
	S 08			453	254	615	416	777	578	940	741	102	903	1264	1065	1426	1227	1524	1325	558	359
	S 09					570	346	732	509	895	671	957	833	1219	995	1382	1158	1479	1255	627	404
	S 10							688	439	850	601	1012	763	1174	926	1337	1088	1434	1185	697	449
	S 11									805	531	967	694	1130	856	1292	1018	1389	1116	767	493
	S 12													1085	786	1247	949	1344	1046	837	538
AT 350	S 05	687	470	949	732	1211	994	1474	1257	1736	1519	1998	1781	2260	2044					580	363
	S 06	614	354	876	616	1139	878	1401	1141	1663	1403	1926	1665	2188	1928	2450	2190			696	435
	S 07	541	238	804	500	1066	762	1328	1025	1591	1287	1853	1549	2115	1812	2378	2074	2535	2231	812	508
	S 08			731	384	993	646	1256	909	1518	1171	1780	1433	2043	1696	2305	1958	2463	2115	928	581
	S 09					921	530	1183	793	1446	1055	1708	1317	1970	1580	2233	1842	2390	1999	1044	653
	S 10							1111	677	1373	939	1635	1201	1898	1464	2160	1726	2317	1883	1160	726
	S 11									1300	823	1563	1085	1825	1348	2087	1610	2245	1767	1276	798
	S 12													1753	1232	2015	1494	2172	1652	1392	871
AT 400	S 05	888	623	1226	961	1564	1299	1902	1637	2240	1976	2578	2314	2916	2652					729	465
	S 06	795	477	1133	815	1471	1154	1809	1492	2147	1830	2485	2168	2823	2506	3161	2844			875	558
	S 07	702	331	1040	670	1378	1008	1716	1346	2054	1684	2392	2022	2730	2360	3069	2698	3271	2901	1021	651
	S 08			947	524	1285	862	1623	1200	1961	1538	2299	1876	2637	2214	2976	2552	3178	2755	1167	744
	S 09					1192	716	1530	1054	1868	1392	2206	1730	2544	2068	2883	2407	3085	2609	1313	837
	S 10							1437	908	1775	1246	2113	1584	2452	1923	2790	2261	2993	2464	1459	930
	S 11									1682	1100	2020	1439	2359	1777	2697	2115	2900	2318	1604	1023
	S 12													2266	1631	2604	1969	2807	2172	1750	1116
AT 450	S 05	1394	983	1925	1514	2456	2044	2987	2575	3517	3106	4048	3637	4579	4167					1140	729
	S 06	1248	755	1779	1285	2310	1816	2841	2347	3372	2878	3902	3409	4433	3939	4964	4470			1369	875
	S 07	1103	527	1633	1057	2164	1588	2695	2119	3226	2650	3757	3181	4287	3711	4818	4242	5137	4561	1597	1021
	S 08			1488	829	2018	1360	2549	1891	3080	2422	3611	2952	4142	3483	4672	4014	4991	4333	1825	1166
	S 09	811				1873	1132	2403	1663	2934	2194	3465	2724	3956	3255	4527	3786	4845	4104	2053	1312
	S 10							2258	1435	2788	1965	3319	2496	3850	3027	4381	3558	4699	3876	2281	1458
	S 11									2643	1737	3173	2268	3704	2799	4235	3330	4553	3648	2509	1

# IMPERIAL TORQUE RATINGS



# AIR TORQUE

SPRING RETURN TORQUE RATINGS IN LB-IN																	Spring stroke				
Supply Pressure		40 Psi		50 Psi		60 Psi		70 Psi		80 Psi		90 Psi		100 Psi		110 Psi		116 Psi		90°	0°
Actuator Model	Spring Set	Start	End	Start	End	Start	End	Start	End	Start	End	Start	End	Start	End	Start	End	Start	End	Start	End
AT 600	S 05	3312	2406	4610	3704	5908	5003	7207	6301	8505	7599	9803	8898	11102	10196					2787	1882
	S 06	2935	1849	4234	3147	5532	4445	6830	5744	8129	7042	9427	8340	10725	9639	12024	10937			3345	2258
	S 07	2559	1291	3857	2589	5156	3888	6454	5186	7752	6485	9051	7783	10349	9081	11648	10380	12427	11159	3902	2634
	S 08			3481	2032	4779	3330	6078	4629	7376	5927	8674	7225	9973	8524	11271	9822	12050	10601	4460	3011
	S 09					4403	2773	5701	4071	7000	5370	8298	6668	9596	7966	10895	9265	11674	10044	5017	3387
	S 10							5325	3514	6623	4812	7922	6110	9220	7409	10518	8707	11297	9486	5575	3763
	S 11									6247	4255	7545	5553	8844	6851	10142	8150	10921	8929	6132	4140
	S 12												8467	6294	9766	7592	10545	8371	6690	4516	
AT650	S 05	5535	4113	7716	6294	9898	8475	12079	10657	14260	12838	16441	15019	18623	17200					4612	3190
	S 06	4897	3190	7078	5372	9260	7553	11441	9734	13622	11915	15803	14097	17985	16278	20166	18459			5534	3828
	S 07	4259	2268	6440	4449	8622	6631	10803	8812	12984	10993	15165	13174	17347	15356	19528	17537	20837	18845	6457	4466
	S 08			5802	3527	7984	5708	10165	7889	12346	10071	14527	12252	16709	14433	18890	16614	20199	17923	7379	5104
	S 09					7346	4786	9527	6967	11708	9148	13889	11329	16071	13511	18252	15692	19561	17001	8302	5742
	S 10							8889	6045	11070	8226	13251	10407	15433	12588	17614	14770	18923	16078	9224	6380
	S 11									10432	7303	12613	9485	14795	11666	16976	13847	18285	15156	10147	7018
	S 12												14157	10743	16338	12925	17647	14233	11069	7656	
AT 700	S 05	7836	5576	11002	8742	14168	11907	17333	15073	20499	18239	23665	21405	26831	24571					7088	4828
	S 06	6870	4158	10036	7324	13202	10490	16368	13656	19534	16822	22700	19987	25865	23153	29031	26319			8505	5793
	S 07	5905	2741	9071	5906	12236	9072	15402	12238	18568	15404	21734	18570	24900	21736	28066	24902	29965	26801	9923	6759
	S 08			8105	4489	11271	7655	14437	10821	17603	13986	20769	17152	23934	20318	27100	23484	29000	25384	11340	7724
	S 09					10305	6237	13471	9403	16637	12569	19803	15735	22969	18901	26135	22067	28034	23966	12758	8490
	S 10							12506	7986	15672	11151	18837	14317	22003	17483	25169	20649	27069	22549	14176	9655
	S 11									14706	9734	17872	12900	21038	16066	24204	19231	26103	21131	15593	10621
	S 12												20072	14648	23238	17814	25138	19713	17011	11586	
AT 800	S 05																				
	S 06																				
	S 07																				
	S 08																				
	S 09																				
	S 10																				
	S 11																				
	S 12																				

N° of Springs: The above value are the out-put torque that remain available to operate the valve when the port "Z" is pressurized.

Out-put torque available when air supply fails

DOUBLE ACTING TORQUE RATINGS IN LB-IN									
Supply Pressure Model	40 Psi	50 Psi	60 Psi	70 Psi	80 Psi	90 Psi	100 Psi	110 Psi	116 Psi
AT 050 D	81.1	101	122	142	162	183	203	223	235
AT 100 D	143	179	215	251	286	322	358	394	415
AT 200 D	284	355	426	497	568	639	710	781	824
AT250 D	447	559	670	782	894	1005	1117	1229	1296
AT 300 D	649	811	974	1136	1298	1461	1623	1785	1883
AT 350 D	1049	1312	1574	1836	2099	2361	2623	2886	3043
AT400 D	1352	1691	2029	2367	2705	3043	3381	3719	3922
AT450 D	2123	2654	3185	3716	4246	4777	5308	5839	6157
AT500 D	2770	3462	4155	4847	5540	6232	6925	7617	8032
AT550 D	3739	4674	5609	6544	7479	8413	9348	10283	10844
AT600 D	5193	6492	7790	9088	10387	11685	12984	14282	15061
AT650 D	8725	10906	13087	15269	17450	19631	21812	23994	25302
AT700 D	12663	15829	18995	22161	25327	28493	31659	34825	36724
AT800 D									

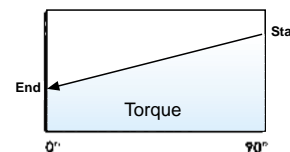
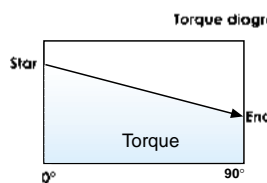
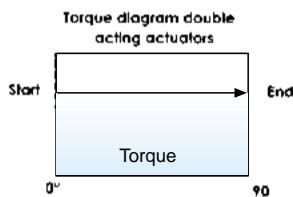



**AIR TORQUE**

**TECHNICAL DATA FOR 120° AND 180° ACTUATORS IN METRIC AND IMPERIAL DIMENSIONS**

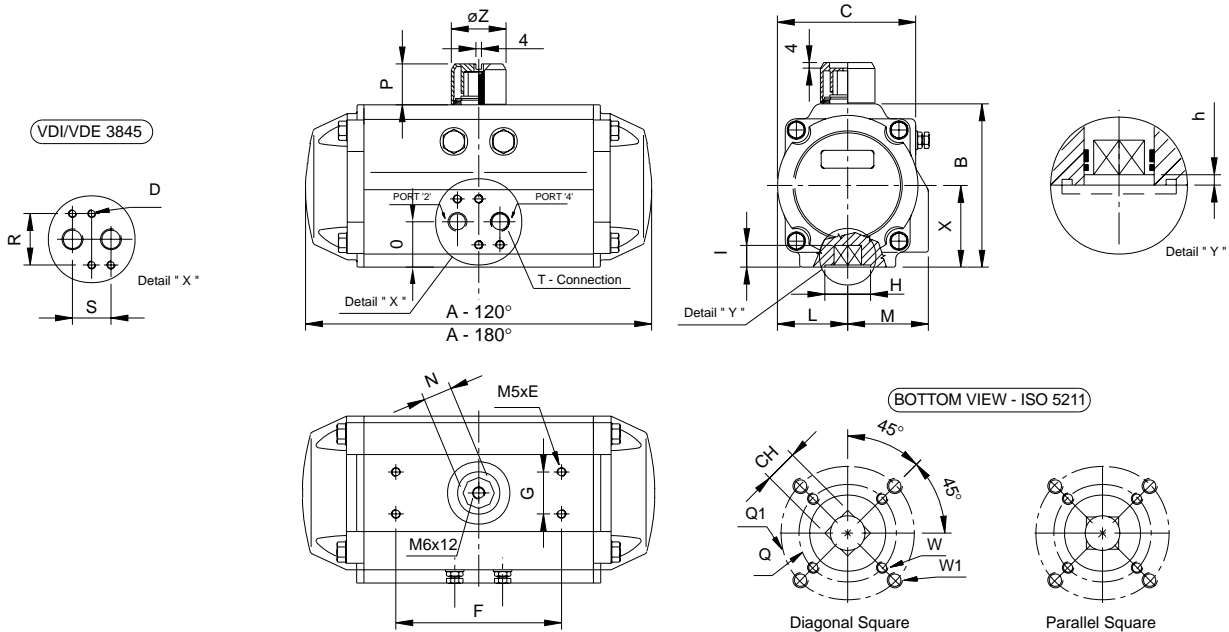

Dimensions in mm								
MODEL	AT050	AT100	AT200	AT250	AT300	AT400	AT500	AT600
A - 120°	159.5	179.5	240	281	304	395	500	618
A - 180°	197	221.5	298.5	348	381.5	496	626	-
B	29	85	62	115	127	157	195	245
C	59	72	84.5	97.5	111	136	169	213
D	M5x8	M5x8	M5x8	M5x8	M5x8	M5x8	M5x8	M5x8
E	4	8	8	8	8	8	8	8
F	80	80	80	80	80	80	80	130
G	30	30	30	30	30	30	30	30
H	30	35	35	35	35	70	85	100
I min.	12	16	16	19	19	74	79	38
L	29	36	42.5	49.5	56	69.5	88	110
M	41.5	47	52	56.8	67	82	99	112
N	11	19	19	19	19	27	27	42
O	26.5	30	30.5	32.5	37.5	45	52	67
P	20	20	20	20	20	30	30	50
Q	42	50	50	70	70	102	125	140
Q1	-	-	-	-	-	-	-	-
R	32	32	32	32	32	32	32	32
S	24	24	24	24	24	24	24	24
W	M5	M6	M6	M8	M8	M10	M12	M16
W1	-	-	-	-	-	-	-	-
T - ISO 228	1/8	1/8	1/8	1/8	1/4	1/4	1/4	1/4
ISO Flange	F04	F05	F05	F07	F07	F10	F12	F14
CH	11	14	14	17	17	22	27	36
h min.	0.5	0.5	1.5	1.5	5	1.5	1.5	2
X	34.5	42.5	51	37.5	63.5	78.5	98	122
Z	40	40	40	40	40	50/65	65	80/115

Dimensions in inch								
MODEL	AT050	AT100	AT200	AT250	AT300	AT400	AT500	AT600
A - 120°	6.28	7.07	9.45	11.04	12.05	15.55	19.69	24.33
A - 180°	7.74	8.72	11.75	13.70	15.02	19.53	24.65	-
B	2.72	3.35	4.02	4.53	5.00	6.18	7.77	9.65
C	2.32	2.83	3.30	3.84	4.37	5.35	6.65	8.39
D	M5x8	M5x8	M5x8	M5x8	M5x8	M5x8	M5x8	M5x8
E	0.16	0.31	0.31	0.31	0.31	0.31	0.31	0.31
F	3.15	3.15	3.15	3.15	3.15	3.15	3.15	5.12
G	1.18	1.18	1.18	1.18	1.18	1.18	1.18	1.18
H	1.18	1.39	1.38	2.17	2.17	2.76	3.35	3.94
I min.	0.47	0.63	0.63	0.75	0.75	0.94	1.14	1.50
L	1.14	1.42	1.67	1.95	2.20	2.74	3.45	4.33
M	1.63	1.65	2.05	2.74	2.64	3.23	3.90	4.41
N	0.43	0.43	0.75	0.75	0.75	1.06	1.06	1.65
O	1.04	1.18	1.20	1.28	1.48	1.77	2.05	2.44
P	0.79	0.79	0.79	0.79	0.79	1.18	1.18	1.97
Q	1.65	1.97	1.97	2.76	2.76	4.02	4.92	5.51
Q1	-	-	-	-	-	-	-	-
R	1.26	1.26	1.26	1.26	1.26	1.26	1.26	1.26
S	0.94	0.94	0.94	0.94	0.94	0.94	0.94	0.94
W	M5	M6	M6	M8	M8	M10	M12	M16
W1	-	-	-	-	-	-	-	-
T - ISO 228	1/8	1/8	1/8	1/8	1/4	1/4	1/4	1/4
ISO Flange	F04	F05	F05	F07	F07	F10	F12	F14
CH	0.43	0.55	0.55	0.67	0.67	0.87	1.06	1.42
h min.	0.02	0.02	0.06	0.06	0.06	0.06	0.06	0.08
X	1.36	1.67	2.01	2.26	2.50	3.09	3.86	4.80
Z	1.57	1.57	1.57	1.57	1.57	2.20/2.36	2.56	3.15/4.53

Note: For optional dimensions of ISO flange and square size on bolt/side, see Metric and Imperial dimensions of standard 90° Actuator.

	MODEL TYPE	AT050 D		AT100 D		AT200 D		AT250 D		AT300 D		AT400 D		AT500 D		AT600 D			
		120° Y	180° X	120° Y	180° X	120° Y	180° X	120° Y	180° X	120° Y	180° X	120° Y	180° X	120° Y	180° X	120° Y	180° X		
METRIC	Chamber	ø (mm)		50	63	63	75	75	85	85	100	100	125	125	160	160	200	200	
	Screw stroke Adjustment	For 1° adj. need		1/6 turn	1/6 turn	1/6 turn	1/6 turn	1/6 turn	1/6 turn	1/5 turn	1/5 turn	1/5 turn	1/4 turn	1/4 turn	1/4 turn	1/4 turn	1/4 turn	1/4 turn	
	Air Volume Opening	{L}		0.11	0.17	0.2	0.29	0.39	0.56	0.63	0.92	0.9	1.3	1.9	2.8	3.9	5.7	7.4	
	Air Volume Closing	{L}		0.18	0.27	0.32	0.47	0.61	0.88	0.97	1.4	1.4	2	2.9	4.2	6.2	8.8	11.8	
	Opening Time t <sub>01</sub>	{Sec.}		0.26	0.31	0.33	0.39	0.39	0.47	0.52	0.63	0.65	0.79	1.17	1.41	1.95	2.36	3.51	
	Closing Time t <sub>01</sub>	{Sec.}		0.33	0.39	0.39	0.47	0.52	0.63	0.65	0.79	0.91	1.10	1.56	1.88	2.34	2.83	4.55	
Approximate weight	{Kg}		1.2	1.5	2	2.5	3.4	4.4	4.6	6	6.6	8.1	12.3	15.4	24.6	29.5	44	-	
IMPERIAL	Chamber	ø (inch)		1.97	1.97	2.48	2.48	2.95	2.95	3.35	3.35	3.94	3.94	4.92	4.92	6.30	6.30	7.87	7.87
	Screw stroke Adjustment	For 1° adj. need		1/6 turn	1/6 turn	1/6 turn	1/6 turn	1/6 turn	1/6 turn	1/5 turn	1/5 turn	1/5 turn	1/4 turn	1/4 turn	1/4 turn	1/4 turn	1/4 turn	1/4 turn	
	Air Volume Opening	{Cu. In.}		6.7	10.4	12.2	17.7	23.8	34.2	38.5	56.2	54.4	79.4	117.3	171.1	239.6	348.3	452.2	-
	Air Volume Closing	{Cu. In.}		11	16.5	19.6	28.7	37.3	53.8	59.3	85.6	84.3	122.2	178.4	256.7	375.8	537.8	721.1	-
	Opening Time t <sub>01</sub>	{Sec.}		0.26	0.31	0.33	0.39	0.39	0.47	0.52	0.63	0.65	0.79	1.17	1.41	1.95	2.36	3.51	
	Closing Time t <sub>01</sub>	{Sec.}		0.33	0.39	0.39	0.47	0.52	0.63	0.65	0.79	0.91	1.10	1.56	1.88	2.34	2.83	4.55	
Approximate weight	{Lbs}		2.6	3.3	4.4	5.5	7.4	9.6	10.1	13.1	14.4	17.7	26.9	33.7	53.8	64.5	96.3	-	

Notes: (A) The above indicated moving time of the actuator, are obtained in the following test conditions: (1) Room Temperature, (2) Actuator Stroke 120° and 180°, (3) Solenoid Valve with Orifice Of 4 mm and a flow capacity Qn 400 L/min., (4) Inside pipe diameter 8 mm, (5) Medium clean air, (6) Air supply pressure 5,5 bar (79,75Psi), (7) Actuator without external resistance load. Cautions: obviously on the field applications when one or more of the above parameter are different, the moving time will be different.

- ◆ 120 and 180° actuator are available only in double acting version
- ◆ other actuator sizes (ex. AT 350 180°) would be evaluated on request
- ◆ Different Actuator strokes other than 120° and 180° (e.g. 135 Stoke) are available on request.

## 3 POSITION ACTUATOR



**AIR TORQUE**

AIR TORQUE 3 position pneumatic actuator provide an operation of 0°- 45°- 90° or 0°-90°-180°. The intermediate position is achieved by a mechanical stop of movement on the 2 auxiliary pistons. This intermediate stop positions adjustable e.g. 90° actuators can provide 20° 30° 50° 75° etc.

In order to control the operation of AT 3 position pneumatic actuators a system of solenoid valves controlling a sequence of air supplies to the actuator is required as described below:

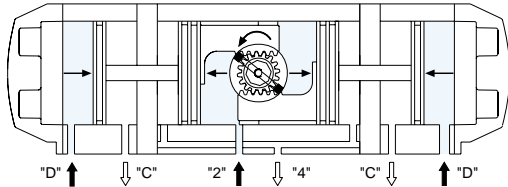

Position 1 (Intermediate Position):

This position is achieved when air is supplied simultaneously to ports 2 and D with exhaust air at ports 4 and C. In fact the air supplied at ports D forces the auxiliary pistons to the center and the rods serve as mechanical stops for the internal pistons in the desired intermediate position.

Position 2 (Fully Open Position):

This position is achieved when air is supplied to port 2 and port C (Air to port C may also be avoided) with exhaust air at port 4. In this condition air to port 2 permit to internal pistons to continue the opening stroke.

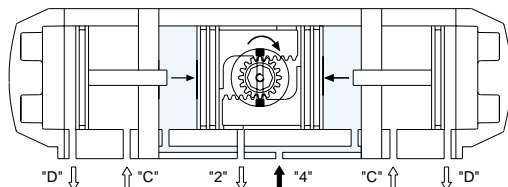
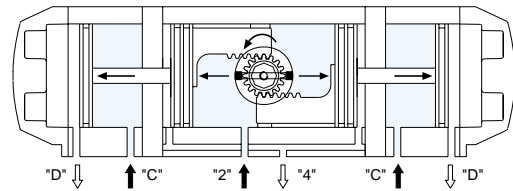

Position 3 (Fully closed Position):

This position is obtained when air is supplied to port 4 with exhaust air at port 2.

## SIZING INFORMATION

The aim of this information is to assist in the correct selection of AIR TORQUE actuators. Before fitting an AT actuator onto any valve the following data must be considered:

- breakaway torque of the valve + safety factor as recommended by the manufacturer/considering the operating conditions.
- air supply pressure available to the actuator
- type of actuator "D" (double acting) or "S" (spring return) and output torque of actuator at the available air supply pressure
- actuator rotation and the fail mode (to fail open or to fail close)

The correct selection of an actuator is critical, if the actuator is oversized the valve stem can be overstressed, on the contrary if the actuator is undersized it cannot produce enough torque to permit full valve operation.

Generally we can say that the torque required for valve operation comes from the friction between the metallic parts of the valve (for example ball or disc) and the seals (seats).

Moreover the torque is influenced by various factors depending on the type of application of the valve (service condition): service temperature, operation frequency, line and differential pressure, flow media (lubricated, dry or slurry).

The following examples show the torque characteristic for 3 types of quarter-turn valves: ball valve, butterfly valve and plug valve.

### BALL VALVE

Ball valve concept of construction is based essentially on a polished ball (including a through port) contained between two seats (upstream and downstream). The ball rotation allows the flow or stops the flow through the valve. Differential of pressure between upstream and downstream pressure forces the ball against the downstream seat (floating ball design). In this case the valve torque is generated by the friction between the ball, seat, stem and packing.

As shown in the diagram below the highest point of torque occurs when with the presence of pressure, and the ball in the closed position, the valve is moved to the open position (breakaway torque).

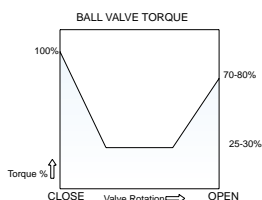

### BUTTERFLY VALVE

Butterfly valve concept of construction is based essentially on a disc fixed on an axis. In the closed position the disc is completely contained by the seat. The open position is achieved when the disc is rotated (through its stem) becomes parallel to the flow.

On the contrary, the closed position is achieved when the disc is perpendicular to the flow. With a butterfly valve the torque is generated by the friction between the disc, seat and the stem packing. Also torque may be effected by the differential pressure that forces on the disc. The highest point of torque, as shown in the diagram below, is in the closed position, and after only a small rotation torque is considerably reduced.

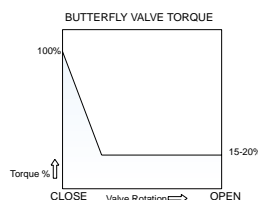

### PLUG VALVE

Plug valve concept construction is based essentially on a male (plug) contained in a female cone (seat). The plug provides a through port in one direction and with its rotation into the seat the opening and closure of the valve is achieved.

The torque is usually not influenced by the flow pressure, but is generated essentially by the friction between the seat and the plug, during the opening + closing cycle. The highest point of torque as shown in the diagram below, occurs in the closed position and remains high for the rest of the operation, because the torque is not influenced by pressure.

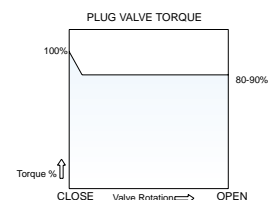



## SIZING: DOUBLE ACTING ACTUATOR

With rack and pinion construction the output torque of an actuator is obtained by multiplying the piston force (given by air supply pressure) by the pitch shaft radius (lever arm) as shown in fig. 1 less the force lost for friction (efficiency). Because of this concept, the output torque is linear as shown in the diagram A in both clockwise and counterclockwise rotation. The suggested safety factor for double acting actuators in normal working conditions is 15-20%.

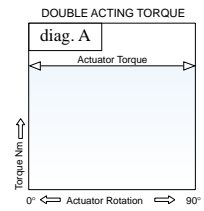
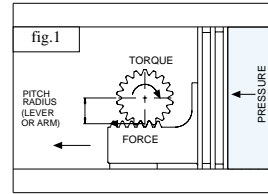

Sizing example of Double Acting AT actuator (see also technical data):

- Published butterfly valve torque = 40Nm
- Safety factor (20%) = 40 Nm + 20% = 48 Nm
- Air supply pressure available = 5 bar

The double acting AT actuator that produces a minimum of 48 Nm at 5 bar is AT200 (see also the diagram B).

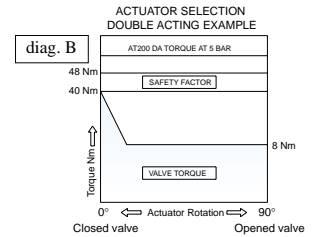

## SIZING: SPRING RETURN ACTUATOR

In spring return applications the output torque is obtained in two different operations as shown in fig. 2 and 3. Each operation produces two different values in relation to the stroke position (0° or 90°). For spring return actuators the output torque is produced by multiplying the force (air or springs acting on the pistons) by the lever arm.

First condition (fig. 2): output torque is generated by air supply pressure at Port 2 after compressing the springs, called "OUTPUT TORQUE AIR STROKE". In this case air forces the pistons from the 0° to the 90° position and consequently the torque starts from a high value and during the stroke it constantly decreases until 90° due to the natural force that springs generate (oppose) when they are compressed (see diagram C).

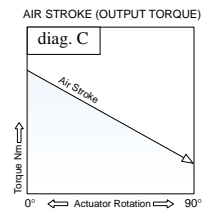
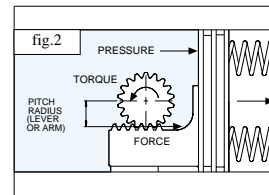

Second condition (fig. 3): output torque is generated by the force that springs release onto the pistons when air fails, called "OUTPUT TORQUE SPRING STROKE". In this case the torque, starting from the 90° position, constantly decreases until 0° because of springs extending (see diagram D).

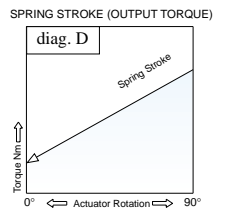
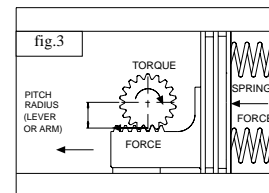

AT spring return actuator are designed to produce a balanced torque in the two conditions explained above when the number of springs per side is equal to the air pressure supply (4 bar - 4 springs each side) as shown in diagram E. For certain applications it is possible to achieve (where desired), the unbalanced torque, as shown in diagram F, by changing the relation between the number of springs per side and air pressure supply in bar (for example 6 springs and 5.5 bar or vice versa).

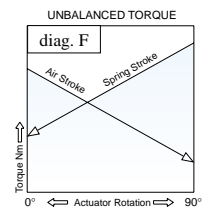
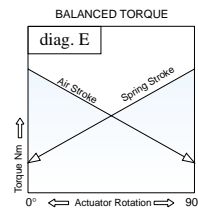

In spring return applications two conditions can be achieved: air failure to close or air failure to open. The suggested safety factor for spring return actuators in normal working conditions is 20-25%.

Sizing example of AT Spring Return actuator (see also technical data):

Spring to close (when air fails)

- Published ball valve torque = 80 Nm
- Safety factor (20%) = 80 Nm + 20% = 96 Nm
- Air supply pressure available = 5 bar

The spring return AT actuator selected is AT400 S10, because it produces the following values:

- spring stroke 0° = 105 Nm
  - spring stroke 90° = 165 Nm
  - air stroke 0° = 172 Nm
  - air stroke 90° = 112 Nm
- (See also the diagram G).

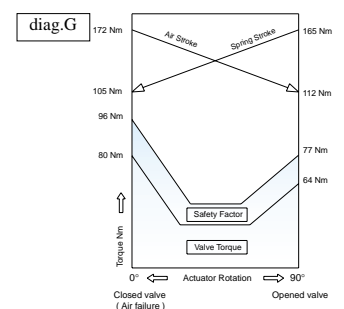



# PROTECTIONS LEVELS FOR 4th GENERATION ACTUATOR



**AIR TORQUE**

## PROTECTION LEVELS AVAILABLE

Components	A	B	C
Body	Alodur (Special hard anodized) Colour: Bright Stainless steel	Alodur + PTFE coating Colour: Light grey	ENP+ Polyester transparent Coated Colour: Bright Stainless steel
End-caps	Chromatized + Polyester Coated Colour: S.S. Ral 9007 or Blue Ral 5015	Chromatized + Polyester Coated Colour: S.S. Ral 9007 or Blue Ral 5015	Chromatized + Polyester Coated Colour: S.S. Ral 9007
Drive shaft	Carbon Steel ENP	Carbon Steel ENP	Carbon Steel ENP
Pistons	Normal Anodized Colour: Black	Normal Anodized Colour: Black	Normal Anodized Colour: Black
Suitable for:	-General service	-General service -Acids or basic solutions in low concentration	-General service -Caustic soda in low concentration
Not recommended for:	Caustic Soda -All strong acids or basic solutions	-Nitric acid -N-Methyle Pirolidone (solvent)	Nitric acid -Chlorine, sulphuric and salted environment
Salt Spray Test Certif. N°	SAC/655/98	SAC/656/98	SAC/892/96
Kesternick Test Certif. N°	SAC/299/98	SAC/300/98	SAC/895/96

ENP= Electroless nickel coating  
High Phosforous content P>10%



## PROTECTION LEVEL

Components	D	E	P
Body	Alodur + PTFE coating Colour: Light grey	Alodur + PTFE coating Colour: Light grey	Alodur (special hard anodized) Colour: Bright Stainless steel
End-caps	Chromatized + PTFE coating Colour: Light grey	Chromatized + PTFE coating Colour: Light grey	Resin Impregnated + Hard Anodized Colour: Dark gray
Drive shaft	Carbon Steel ENP	S.S. 303 (Option 316)	Carbon Steel ENP
Pistons	Normal Anodized Colour: Black	Normal Anodized Colour: Black	Normal Anodized Colour: Black
Suitable for:	-General service -Acids or basic solutions in low concentration	-General service -Acids or basic solutions in low concentration	-General service Suggested for any kind of solvent
Not recommended for:	-Nitric acid -N-Methyle Pirolidone (solvent)	-Nitric acid -N-Methyle Pirolidone (solvent)	-Caustic soda -All strong acids or basic solutions
Salt Spray Test Certif. N°	SAC/890/96	SAC/886/96	SAC/304/98
Kesternick Test Certif. N°	SAC/896/96	SAC/897/96	SAC/301/98

ENP= Electroless nickel coating  
High Phosforous content P>10%





AIR TORQUE 4th Generation actuator are designed in full compliance with the latest worldwide specifications relating to the actuator accessory and valve mounting interfaces.

Bottom mounting pad (Actuator to valve interface) configured in accordance with ISO 5211 and DIN 3337 specifications



◆ ISO 5211 and DIN 3337 configuration permits easy installation of the actuator directly onto a valve or will interface through an ISO bracket. ISO gear boxes.

◆ AIR TORQUE can supply all mounting kits i.e. Assorted Square drive reducer pieces suitable for all square drive shaft, Centering rings for all sizes, Brackets and Couplings.



Other than the standard bottom ISO/DIN Parallel or Diagonal square output on the drive shaft connection, we can supply a Keyed connection, Flat head connection or special customized drive connections.

Top mounting pad configuration is in accordance with VDI/VDE 3845 Namur specification in order to permit simple and easy installation of the ancillary like switch boxes and positioners. AIR TORQUE can supply many different types of switchboxes and positioners for any application.

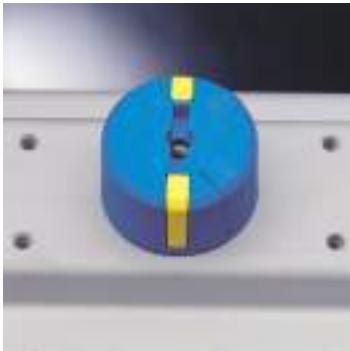

Air supply connection is in accordance with VDI/VDE 3845 Namur specification to provide simple and easy solenoid valve installation, direct mount avoiding piping and fittings. AIR TORQUE can also supply Namur solenoid valves: 5/2 and 3/2 way in all standard voltages, D.C. or A.C.

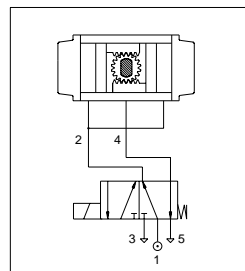

5/2 SOLENOID VALVE OPERATION

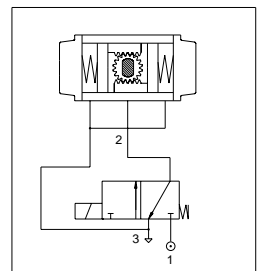

3/2 SOLENOID VALVE OPERATION

# HOW TO ORDER 4th GENERATION ACTUATORS



**AIR TORQUE**

All dimensions, materials and protections are referred to updated catalogue and/or technical data sheet.

Model	Type	Spring Q.TY	TYPE OF PROTECTION	Flange type (2)		Square (3)		POSITION INDICATOR (4)	Seals
AT 050		Only for		F04	F03	11	9	Standard (already included no need to be specified)	Standard NBR seals (no need to be specified)
AT100	D= Double Acting Standard Clockwise to close	Spring	A B C D E F	F05	F04	14	11		
AT200		Return		F05	F05-F07	14	17		
AT250		5		F07	F05-F07	17			
AT300	Do= Double Acting Clockwise to open (1)	6		F07	F05-F07 F07-F10	17	22		
AT350		7		F10	F07-F10	22	17		
AT400		8		F10	F07-F10	22	27		
AT450		9		F12	F10-F12	27			
AT500	S= Spring Return Standard Clockwise to close	10		F12	F10-F12	27			
AT550		11		F14	F12	36	27		
AT600		12		F14	F12	36			
AT650	So= Spring to Open			F16	F14	46	36		
AT700				F16	F14	46			
AT800			F25	F16	55				
				Preferred	Optional	Preferred	Optional		

## NOTES:

- (1) Standard Rotation for double acting and spring return is Clockwise to close (for double acting when port 4 is pressurised).
- (2) When the Centerring (Spigot) is requested the letter Y must be added after the flange type. Example F07Y.
- (3) Standard Square is diagonal square, when parallel square is requested a letter L must be added after the square dimension. Example 22L  
Other type of shaft connection like different square size. Flat head and Keyed bore are available and need a detailed description.
- (4) When indicator for Proximity is requested it must be indicated with letter P. If not specified the actuators will be supplied with standard Position indicator.

Example 1: AT300 D A F07 Y 17

Description: Actuator Model AT300, Type Double Acting (clockwise to close), Protection A, with Flange F07 plus centerring, with diagonal square of 17 mm, with standard indicator and standard NBR seals.

Example 2: AT550 So 10 B F14 36L P HT

Description: Actuator Model AT550, Type Spring return (Spring to open), with 10 springs (5 per side), Protection B, with Flange F14, with Parallel square of 36 mm, with indicator for proximity and FPM seals for high temperature.

## QUALITY PRODUCT

- ◆ Each individual actuator is factory inspected and tested.
- ◆ Each individual actuators are supplied with certificate of Conformity.
- ◆ Each individual actuator has a serial number for full traceability.
- ◆ Each individual actuator is individually packed in a special cardboard carton for protection, with a product description label for easy identification and includes installation, operation and maintenance instructions in 5 languages.

Cad system for Design



Controlled Honing of the internal surface



Electronic torque test machine



The AIR TORQUE actuators are manufactured to a quality system independently assessed and approved to ISO 9001.

## AVAILABLE STANDARD DOCUMENTATIONS

- ◆ Company profile
- ◆ Catalogue 4thG. /99
- ◆ Catalogue 4thG.-R /99
- ◆ Manual Instruction IMAT4G01/99
- ◆ Technical data sheet
- ◆ Corrosion test certificates



**AIR TORQUE**<sup>®</sup>

Head office and Works:  
 AIR TORQUE S.p.A.  
 Via alla Campagna, n°1  
 24060 COSTA DI MEZZATE (BG) Italy  
 Tel.: +39 035 682299 - Fax.: +39 035 687791  
 E-mail: info@airtorque.it  
 internet:www.airtorque.it



## AIR TORQUE'S SALES ORGANIZATIONS



PHOTO: A. FINAZZI

● MAIN DISTRIBUTORS:

Norway, Sweden, Finland, Denmark, Netherlands,  
 Belgium, Switzerland, Austria, Spain, Greece

USA, Canada  
 Australia, New Zeland, South Africa

Poland, Chek Republic, Slovakia, Israel  
 Japan, Korea, Taiwan, Singapore  
 Brasil, Argentina

● AFFILIATED COMPANIES:

AIR TORQUE GmbH  
 Im Katzentach 16-18  
 76275 Ettlingen  
 Germany  
 Tel.: +49 7243 59340  
 Fax.: +49 7243 593434  
 E-mail: info@airtorque.de

A.T. (UK) Ltd  
 4a Sovereign Business Park  
 Lathkill Street  
 Leicestershire  
 LE16 9EG  
 Tel.: +44 1858 468199  
 Fax.: +44 1858 468187  
 E-mail: atukltd@aol.com

AIR TORQUE France (division de STF)  
 Parc D'Activités de la Verdière  
 13880 Velaux  
 France  
 Tel.: +33 4 42878400  
 Fax.: +33 4 42878404

Your Representative: